

Road Light Instruction manual

For retention and reference

● Installation of this product/ luminaire must be carried out by a qualified electrician in accordance with the national, local electric and construction codes and regulations. Installation by unqualified person is prohibited by law.

Product Name	Power	Rated voltage	Rated Current	frequency	Weight
LLF0139A/LEN1/168/E/IN/A	167W	100~240Vac	100Vac 1.69A 240Vac 0.72A	50/60Hz	~10 kg
LLF0139A/LEN1/144/E/IN/A	140W		100Vac 1.41A 240Vac 0.61A		
LLF0139A/LEN1/120/E/IN/A	121W		100Vac 1.22A 240Vac 0.53A		

Overall Dimensions	734mm × 313mm × 151mm
Maximum Projected area	0.198 m ²
IP classification	IP66
IK classification	IK08
Operation Temperature	- 20~50°C
Mount Height	6~14m
Installation pole	Φ60.5mm (Length ≧ 135mm)

Installation instructions

Installer, please save a copy this instructions manual for retention and reference by the end user.

Attention at installation**WARNING**

Incorrect handling of this product may cause serious personal injury, death and damage to the product and property.

- Please ensure installation is in accordance with mounting instruction. Risk of product fall or fire.
- Do not use the product under the following environment and situation. It will cause electric shock and fire.
 - The unit will fall or not operate if not installed properly:
 - Place exposed directly to organic solvent (Acetone, Ethyl ether, Hexane, etc.).
 - Place where corrosive gas (Hydrogen sulfide, Chlorine, Ammonia, etc.) and flammable gas (Hydrogen, Methane, etc.) is present.
 - Places where flammable liquid (Gasoline, Kerosene, Fuel oil, etc.) is used.
 - Places where humidity exceeds 90% or the product is affected by flood.
 - Places covered by heat insulator and combustible material.
 - Places where the product is buried under snow.
- Don't set it up in the place where the hazard is caused when the icicle drops. It causes the injury by the icicle fall.
- The insulation of the AC cable connected to the luminaire must be free from damage or cracks. -Risk of electric shock and fire.
- Do not disassemble this product, repair or replace any of its components. -Risk of electric shock, fire or the product fall.
- Do not use the product when broken or appears damaged in any way. -Risk of product fall, electric shock and fire.
- Please use the cable indicated on operation method with the performance beyond equality for a used cable.
 - It causes the electric shock, a fire, not lighting when other cables are used.
- When abnormality occurs, turn off the power immediately and contact your distributor for assistance. Continued use of the product risks electric shock and fire.
- Do not connect to power source other than specified for the product. -Risk of electric shock, fire and product will not illuminate.
- Temper Glass may be damaged if a strong shock is applied.
 - Please be careful handing so that scratches will not be attached when carrying or installing the luminaire.

**CAUTION**

There is a possibility that it is assumed to owe injury.

- This product is IP 66.
- Wind pressure resistance is 60m/s. Risk of product fall.
- Be sure to turn off the power supply during product installation or removal. There is a possibility that the product is damaged when the installation or removal of the lighting is done with the power supply turned on. It causes the electric shock, and a fire.
- The luminaire should be positioned so that prolonged staring into the luminaire at a distance closer than 5m is not expected.
- The surface of the product becomes a high temperature immediately after lighting and turning off. Please note it enough.
- Please don't use for a hot spring including sulfur constituent. The brightness becomes dark and causes a life expectancy decline.
- Please don't install apparatus for the sun. Sunlight concentrates, and an LED is damaged and causes the not lighting and fire.

**Caution, risk of electric shock**

The light source and control gear contained in this luminaire shall only be replaced by the manufacturer or his service agent or a similar qualified person.

PART NAME

Cover Glass
(Fixing Screw, ※Don't loosen screw)

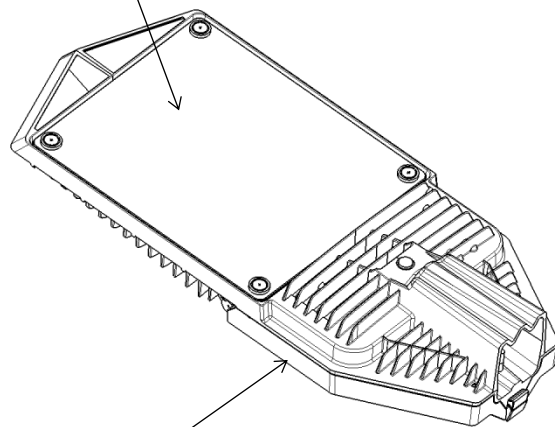

Housing

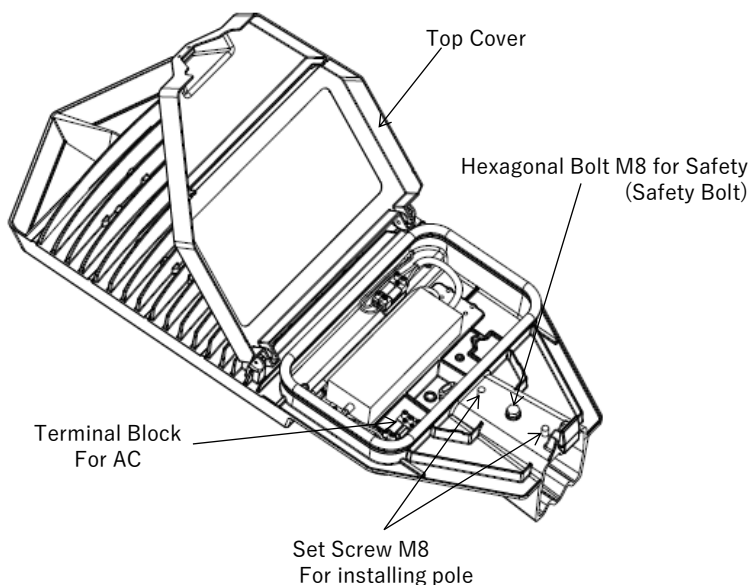

Top Cover

Hexagonal Bolt M8 for Safety
(Safety Bolt)

Terminal Block
For AC

Set Screw M8
For installing pole

Check The Pole Adapter

Please process according to the following because it will cause the instrument to fall.

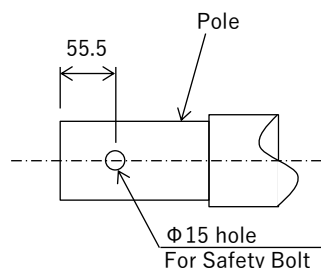
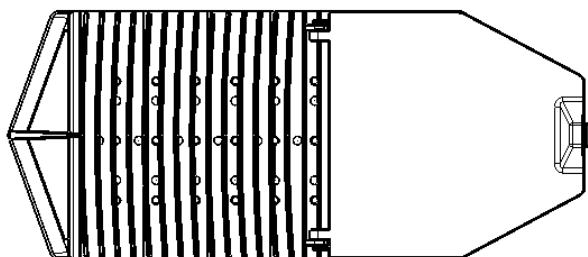

Pole

55.5

Φ 15 hole
For Safety Bolt

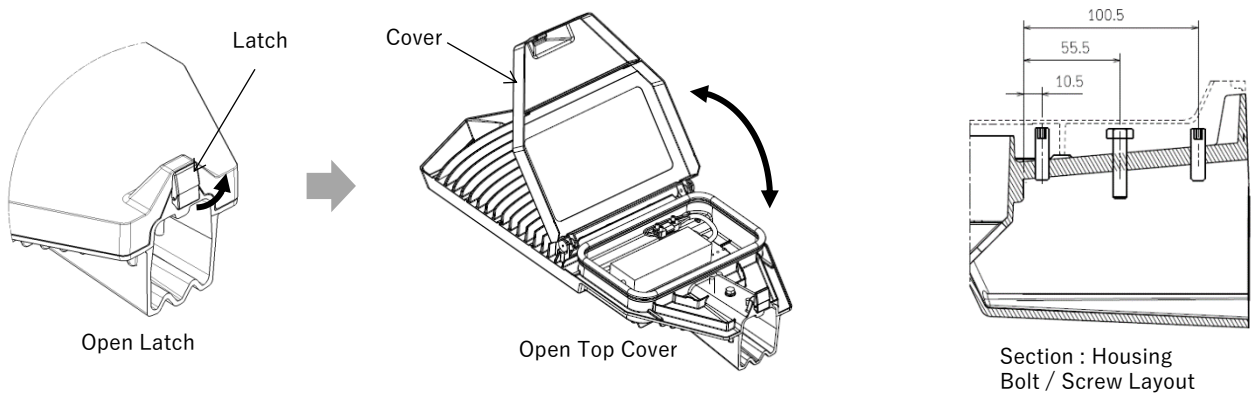
Installation procedure**1. Open cover****2. Install pole by set screw M8.**

Recommended set screw M8 torque : 12.5 N·m

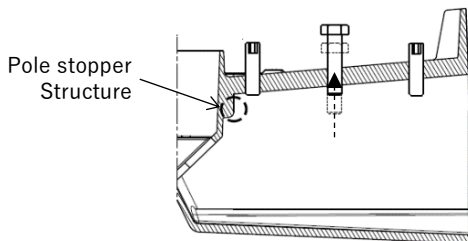
2.1 Move the Hexagonal Bolt M8 up.**2.2 Insert pole to Housing**

Bring the pole into contact with the pole stopper.

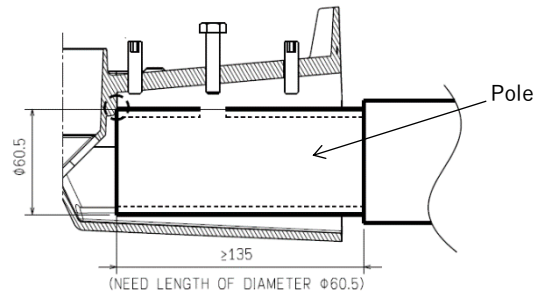
**2.3 Fix the pole by tightening Set Screw M8**

Recommended Set Screw M8 torque : 12.5 N · m

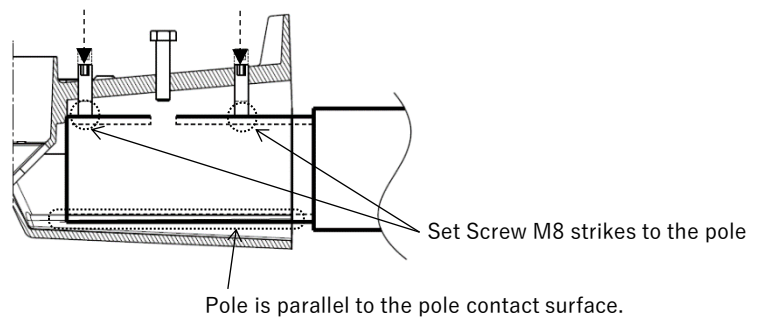
**3. Install Hexagonal Bolt M8 for safety to $\Phi 15$ hole of housing.**

Recommended Hexagonal Bolt M8 torque : 12.5 N · m

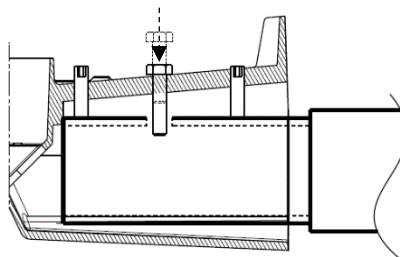

Electrical wire connection method

1. Install AC line cable to Cable gland by tightening the Cable gland.

Recommended torque of Cable gland : 2.2 ~ 3.0 N·m

Requirement of input AC line cable

- Conductor of wire : 2.5 mm²
3-Core : L(R/S/T), N, G
- Available cable sheath size : $\Phi 6 \sim \Phi 11$ mm

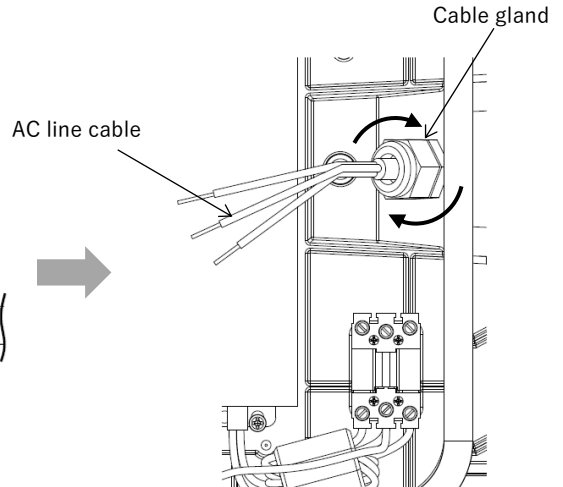
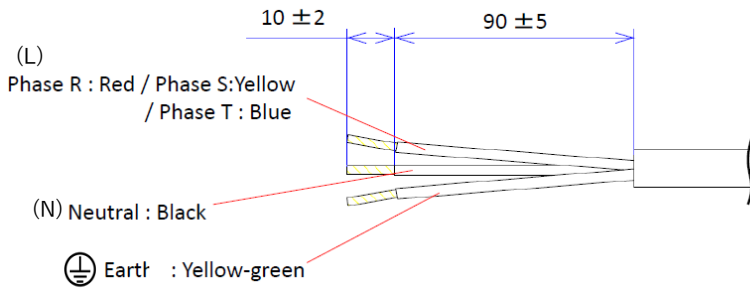

2. Connect wire of AC line cable to Terminal Block (Female)

2.1 Use "+" driver to unscrew M3

2.2 Pull out Terminal Block (Male)

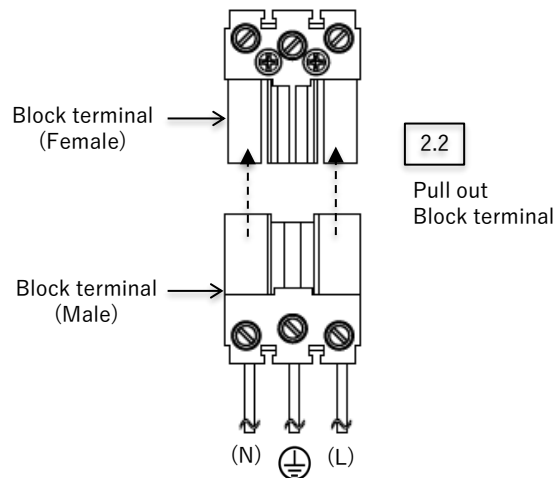
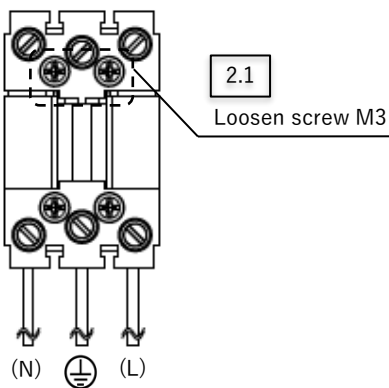

2.3 Connect AC line cable to Terminal Block (Female) by using "-" driver

Recommended screw torque : 2.0 kgf · cm

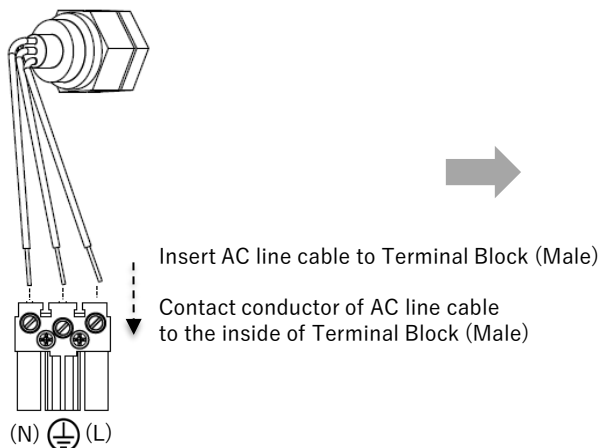

Electrical wire connection method

- 2.4) Assembly Terminal Block (Male) to Terminal Block (Female) by push together until tight.
- 2.5) Fix Block terminal with housing by using screw M3
Recommended screw M3 torque : 6.0 kgf · cm

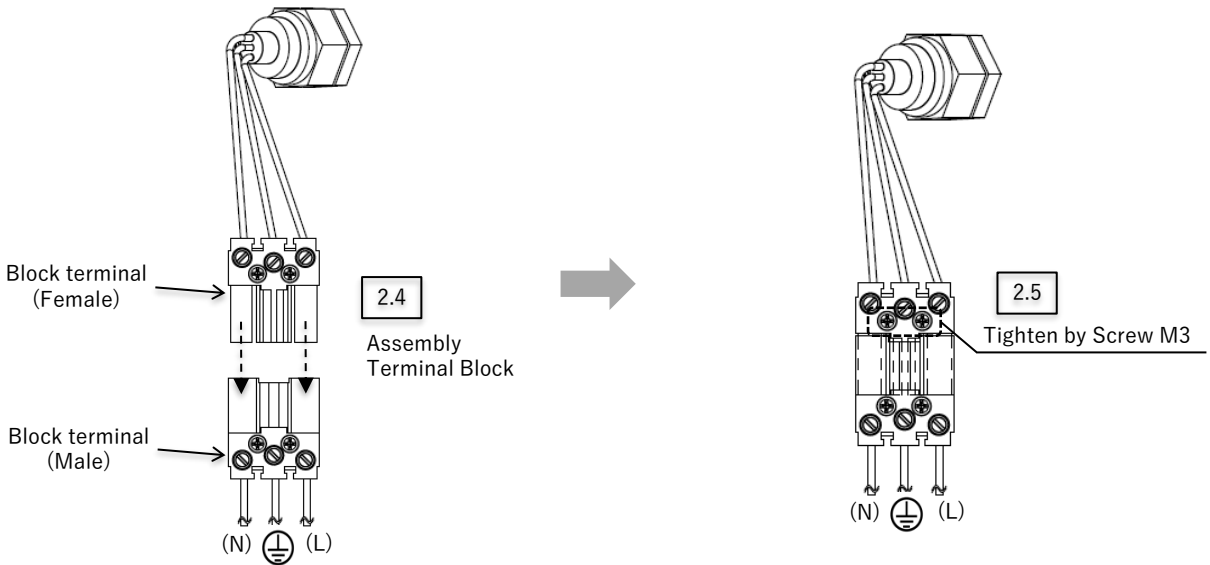

3. Check rubber that must be in a right position.

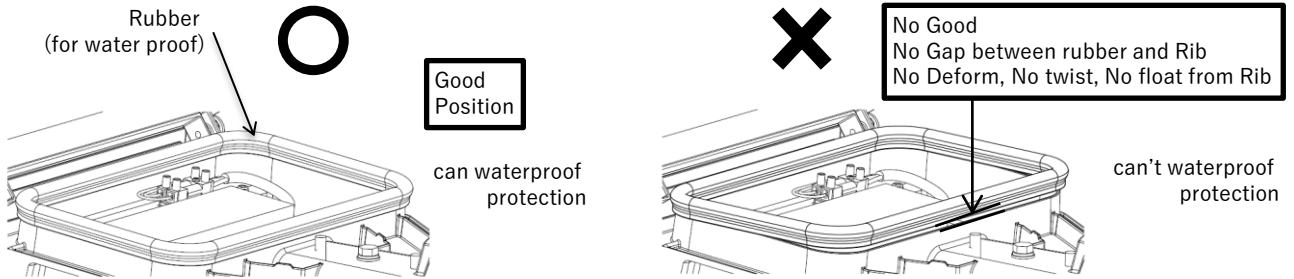

4. Close cover and lock Latch

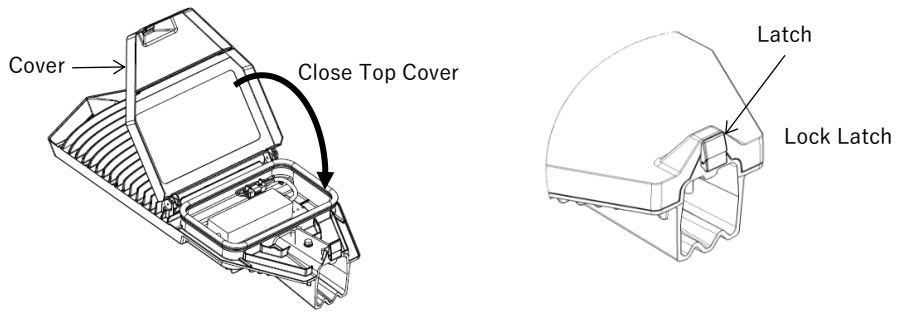

Design Attitude

Install a street light that turns on the floor same as below picture.

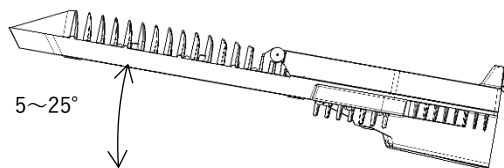

Handling notes

**WARNING**

Incorrect handling of this product may cause serious personal injury, death and/ or damage to the product and property.

- When servicing this luminaire, please strictly follow the instructions in the manual.
- Always turn OFF the power before performing and maintenance.
- Do not disassemble this product, repair or replace any of its components. - Risk of electric shock, fire or the product fall.
- This luminaire uses high bright LED. Do not look directly at light source, it may harm your eyes.

**Caution, risk of electric shock**

The light source and control gear contained in this luminaire shall only be replaced by the manufacturer or his service agent or a similar qualified person.

**CAUTION**

Risk of personal injury when the product is not handled correctly

- Always turn off the power supply and allow the product to cool sufficiently before performing any maintenance
- At higher ambient temperature, life span will be shortened.
- When abnormality occurs, turn off the power immediately and contact your distributor for assistance. Continued use of the product risks electric shock and fire.
- Please do not light up during daytime, except for lighting checks and confirmation.
The internal temperature of the luminaire will rise if operate under direct sunlight.
- When using in snowy condition, please clear snow to prevent the luminaire from being buried in snow .
- It is recommended to clean lens annually. Brightness is reduced when dirt adhered to the lens.
The brightness will return to the original state when the dirt is wiped off.
- Please inspect the luminaire once a year to ensure safe usage.
- Please have the luminaire inspected by a specialist, such as an electrical contractor once every 3 years.
(The luminaire requires thorough inspection when used for 3 years or more.)
Under abnormal operation, there is risk of electric shock and/or the luminaire may fall from the installed location.
- Please understand that the color and brightness may differ between luminaires even for the same model because of variation in LED chips.

Care for your equipment

- Be sure to turn off the power before performing any cleaning.
As the product may be hot after switching off, please wait for a brief interval(20~30 minutes) before cleaning.
- To wipe off dirt on the surface of equipment or cover, use a damp soft cloth
(Squeezed off after soaking in water or Neutral soap water).
- Please do not wipe with thinner, benzene acid, or alkali detergent. It will cause discoloration and the deformation.
- Do not spray water directly on the luminaire with a hose, or clean with a mop or floor brush etc...
It can cause water ingress and or damage to the luminaire.

Warranty

- After receiving, please perform an acceptance inspection promptly and verify the product performance.
If we do not receive report of any problem, we would assume that the product has passed your acceptance inspection.
- The warranty period is stated in the warranty card. We warrant the product is free from defects in manufacturing, materials and workmanship. We may replace your defective product with a similar or improved product at our option. In no event shall we be liable for any special, incidental, consequential or indirect damages.
- The warranty does not cover the followings:
 - ① Failure caused by improper handling and/or misuse.
 - ② Failure caused by alteration to the product and repair by any authorized person.
 - ③ Failure caused by operating in environment and conditions, outside the product specifications.
 - ④ Failure caused by the natural disasters (Fire, Earthquake, Typhoon, etc.)
 - ⑤ Failure caused by dew/ condensation when in operation/ storage temperature and conditions outside the product specifications.
 - ⑥ Failure caused by electrical stress such as excessive voltage surge, including lightning.
- When the root cause of failure could not be determined, both parties should negotiate in good faith for a settlement.
- This product is intended as a light source for illumination applications. We do not assume any responsibility for any damages caused operating the product outside its intended use.

For replacement

- During the warranty period, please produce the proof of purchase date to the distributor(constructor)
- When the warranty period has expired, please consult your distributor(constructor) for replacement.
At your request, we will replace the product at your cost.
- For after-sales service, queries, consultation and replacement, please contact the distributor from which the product was purchased or contact us.
At that time, please inform us of the name of the equipment and the date of purchase.

For product enquiry

- For enquiry, please quote us the product model found on the label on the product.
- Our phone numbers printed in this manual may change. Please visit our homepage for the latest contact information.

ASIAN STANLEY INTERNATIONAL CO.,LTD.

48/1 Moo 1 Kukwang Ladlumkaew, Pathumthanee 12140 Thailand
TEL : +66 2 599 1260

スタンレー電気株式会社

STANLEY ELECTRIC CO.,LTD.

横浜サテライトセンター 〒225-0014 神奈川県横浜市青葉区荏田西2-14-1

Yokohama Satellite Center : 2-14-1 Edanishi, Aoba-ku, Yokohama-shi, Kanagawa, 225-0014 Japan
TEL : +81 45 910 6629

本社 〒153-8636 東京都目黒区中目黒2-9-13

Head office : 2-9-13 Nakameguro, Meguro-ku, Tokyo, 153-8636 Japan
TEL : +81 3 3710 2222