

# Data sheet

Part number :HMDWTJA

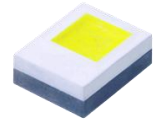

2011/65/EU, (EU)2015/863  
10 Substances regulation compliant



Lead-free solder heat resistant product

Package	SMD Top view Package, White color emitting LED Outer dimension 1.9 x 1.5 x 0.77mm ( L x W x H )
Product features	<ul style="list-style-type: none"> <li>• 3W class, Luminous flux 435lm (Typ.)</li> <li>• Improved color uniformity of white light by 75% (compared to our previous product)</li> <li>• Compact size suitable for high-density mounting</li> <li>• Compliant with AEC-Q102</li> <li>• Equivalent to MSL 2</li> <li>• RoHS compliant</li> <li>• Lead-free soldering compatible</li> </ul>

## Recommended applications

- Exterior light sources for cars and motorcycles (Head lamps, DRLs, fog lamps, logo illumination etc.)

# Outline dimensions

# HMDWTJA

Unit : mm  
 Weight : 7.0mg  
 Tolerance : ±0.1

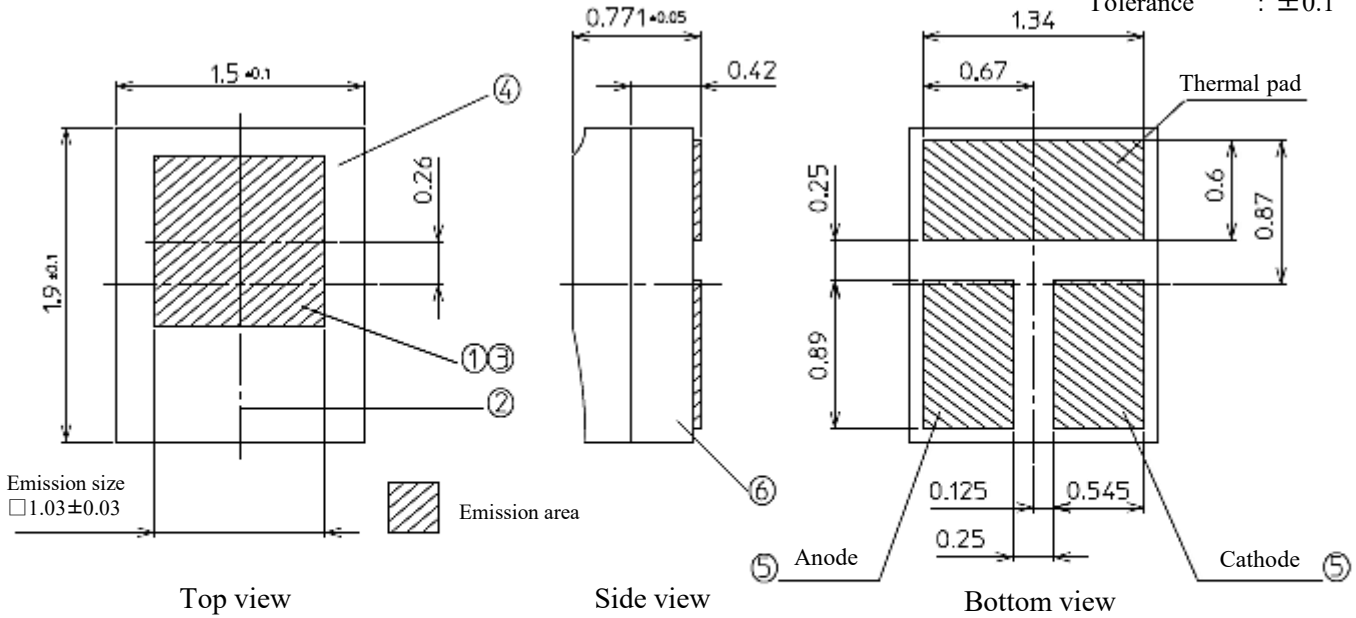

Side view

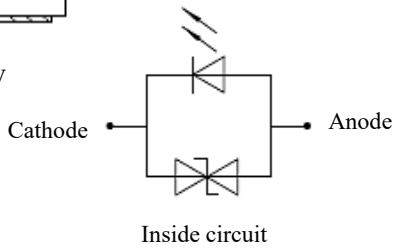

No.	Part name	Material	Qty.
①	LED die	InGaN	1
②	Protection diode	Si	1
③	Plate	Phosphor in glass	1
④	Encapsulant	Silicone resin	1
⑤	Electrode	Au plating	1
⑥	Substrate	AlN	2

## Recommended soldering pattern

Unit : mm

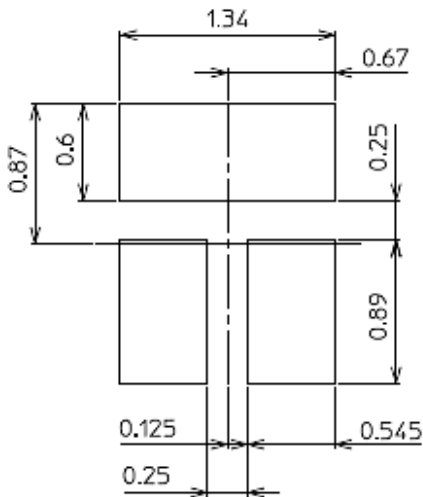

Recommended pad

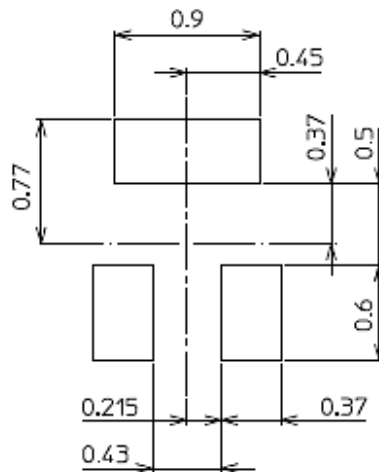

Recommended solder stencil (Mask thickness : 150µm)

# Specifications

HMDWTJA

## 【Product overview】

Die material	InGaN
Emission color	White
Emission area color	Yellow

## 【Absolute maximum ratings】

Item	Symbol	Maximum ratings	Units	
Forward current	$I_F$	10 to 1,500	mA	
Forward current pulsed 【 $T_w \leq 10\mu\text{sec}$ , 0.005 (=1/200) duty】	$I_{FRM}$	2,500	mA	
Operating temperature	$T_{opr}$	-40 to +135	°C	Note1
Storage temperature	$T_{stg}$	-40 to +135	°C	Note1
Electrostatic discharge threshold 【HBM】 ( $T_a = 25^\circ\text{C}$ )	ESD	$\pm 8,000$	V	Note2
Junction temperature	$T_j$	150	°C	
Soldering temperature 【Reflow soldering】	$T_{sld}$	260	°C	

Note1 The temperature range of operating and storage is not for the taping condition, is for the product itself.

Note2 ESD testing method : Human Body Model(HBM) /Acc. to ANSI/ESDA/JEDEC JS-001

## 【Thermal Characteristics】

( $I_F = 1,000\text{mA}$ ,  $T_a = 25^\circ\text{C}$ )

Item	Symbol	Typ.	Max.	Units
Thermal resistance 【Junction - Solder point】	$R_{th(j-s)} \text{ el}$	2.4	3.0	°C/W
Thermal resistance 【Junction - Solder point】	$R_{th(j-s)} \text{ real}$	3.7	4.7	°C/W

## Specifications

## HMDWTJA

## 【Electro-optical characteristics】

(Ta=25°C)

Item	Symbol	Conditions	Min.	Typ.	Max.	Units	
Forward voltage	$V_F$	$I_F = 1,000\text{mA}$	2.80	3.10	3.25	V	Note3
Reverse voltage	$V_R$	Not designed for reverse operation				V	Note4
Luminous flux	$\Phi_V$	$I_F = 1,000\text{mA}$	420	435	550	lm	Note3
Chromaticity coordinates	$C_x$	$I_F = 1,000\text{mA}$	-	0.328	-		Note3,5
	$C_y$		-	0.341	-		
Half intensity angle	$\Delta\theta_x$	$I_F = 1,000\text{mA}$	-	120	-	deg.	Note6
	$\Delta\theta_y$		-	120	-		

Note3 Please refer to the attached sheets, each sorting chart.

Note4 To prevent damage, reverse voltage and reverse current must not be applied.

Note5 Chromaticity coordinates ; x and y according to CIE1931

Note6 Viewing Angle at 50% IV,  $\Delta\theta_X$ ,  $\Delta\theta_Y$ , as shown in the right figure.

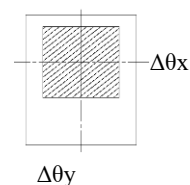

## 【Sorting chart for luminous flux】

LEDs shall be sorted out into the following chart and each rank parts shall be packed separately when shipping.

Rank	Luminous flux $\Phi_V$ (lm)		Conditions
	Min.	Max.	
H2	420	435	$I_F = 1,000\text{mA}$ $T_a = 25^\circ\text{C}$
H3	435	460	
H4	460	480	
H5	480	500	
I1	500	525	
I2	525	550	

Note Tolerance:  $\pm 7\%$

Measurement time : Lighting at moment. (20msec)

## 【Sorting chart for forward voltage】

LEDs shall be sorted out into the following chart and each rank parts shall be packed separately when shipping.

Rank	Forward voltage $V_F$ (V)		Conditions
	Min.	Max.	
A	2.80	3.00	$I_F = 1,000\text{mA}$ $T_a = 25^\circ\text{C}$
B	3.00	3.25	

Note Tolerance:  $\pm 0.1\text{V}$

Measurement time : Lighting at moment. (20msec)

# Specifications

# HMDWTJA

## 【Sorting chart for chromaticity coordinates】

LEDs shall be sorted out into the following chart and each rank parts shall be packed separately when shipping.

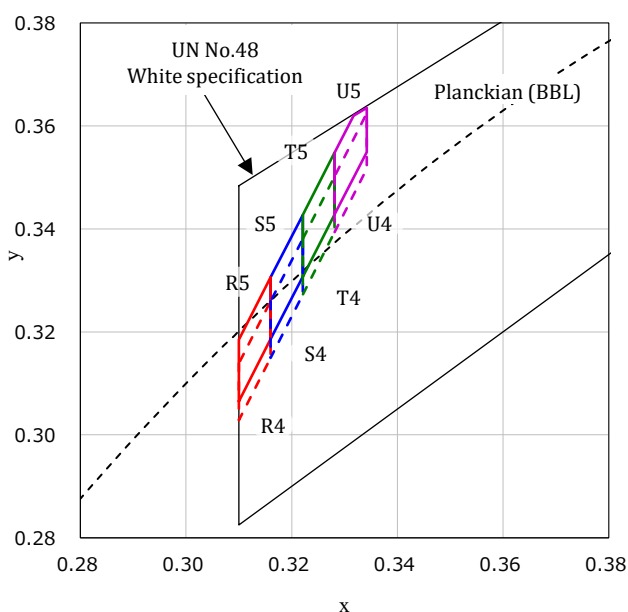
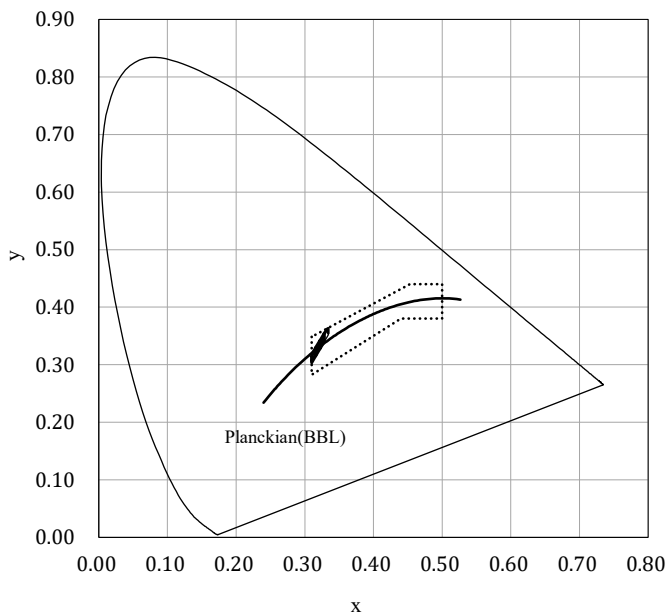

( $I_f=1,000mA$ ,  $T_a=25^{\circ}C$ )

Rank	x	y
R4	0.3100	0.3139
	0.3100	0.3028
	0.3160	0.3149
	0.3160	0.3260

Rank	x	y
S4	0.3160	0.3260
	0.3160	0.3149
	0.3221	0.3272
	0.3221	0.3381

Rank	x	y
T4	0.3221	0.3381
	0.3221	0.3272
	0.3281	0.3393
	0.3281	0.3502

Rank	x	y
U4	0.3281	0.3502
	0.3281	0.3393
	0.3342	0.3516
	0.3342	0.3625

Rank	x	y
R5	0.3100	0.3065
	0.3100	0.3185
	0.3160	0.3306
	0.3160	0.3186

Rank	x	y
S5	0.3160	0.3186
	0.3160	0.3306
	0.3221	0.3427
	0.3221	0.3307

Rank	x	y
T5	0.3221	0.3307
	0.3221	0.3427
	0.3281	0.3548
	0.3281	0.3428

Rank	x	y
U5	0.3281	0.3428
	0.3281	0.3548
	0.3317	0.3620
	0.3342	0.3635
	0.3342	0.3549

Note Tolerance:  $\pm 0.01$   
 Measurement time : Lighting at moment. (20msec)

# Technical Data

# HMDWTJA

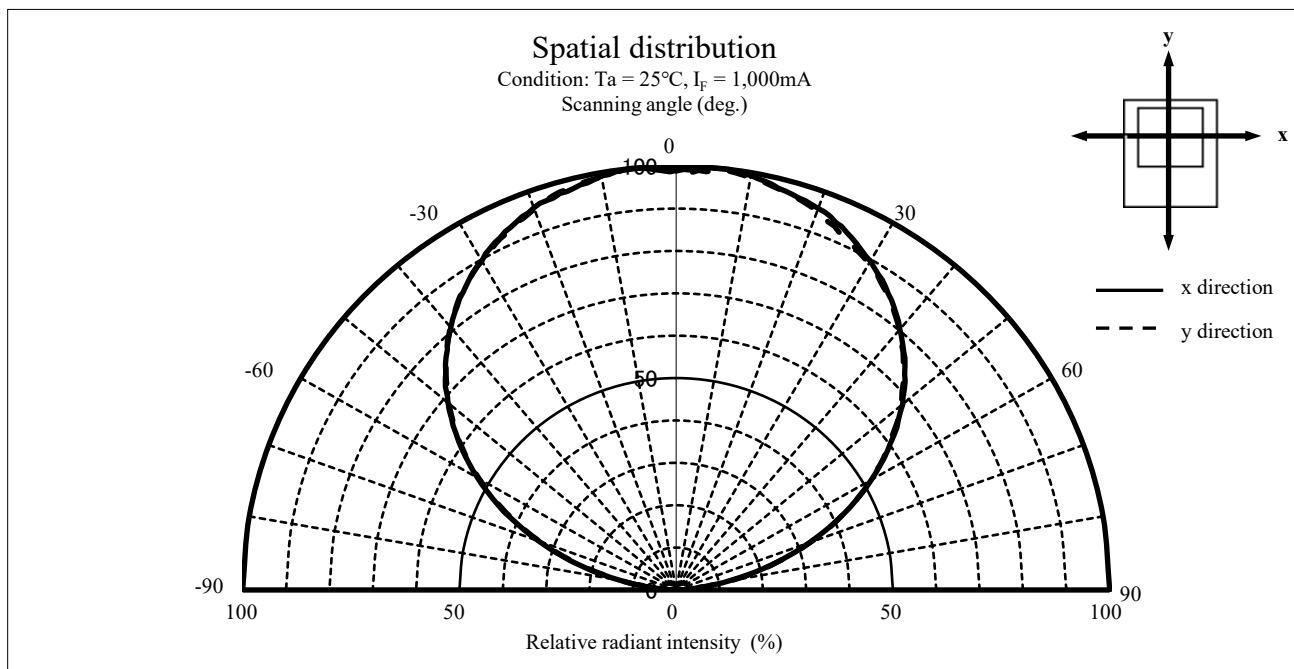
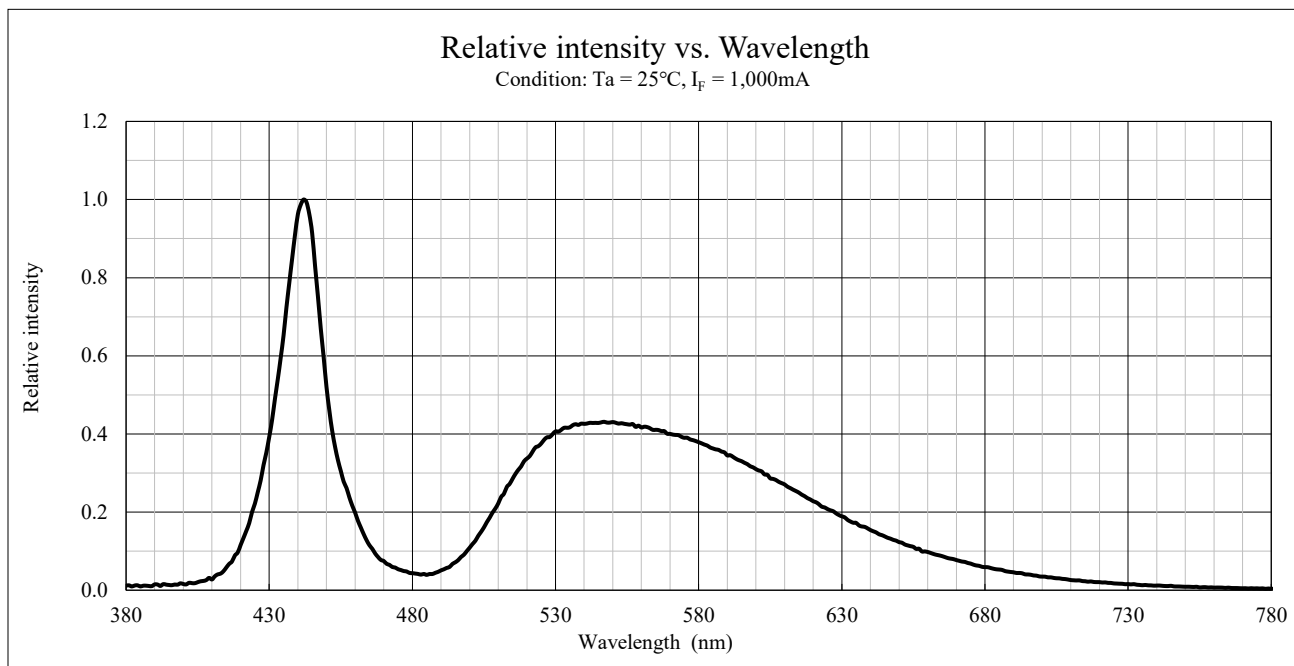

# Technical Data

# HMDWTJA

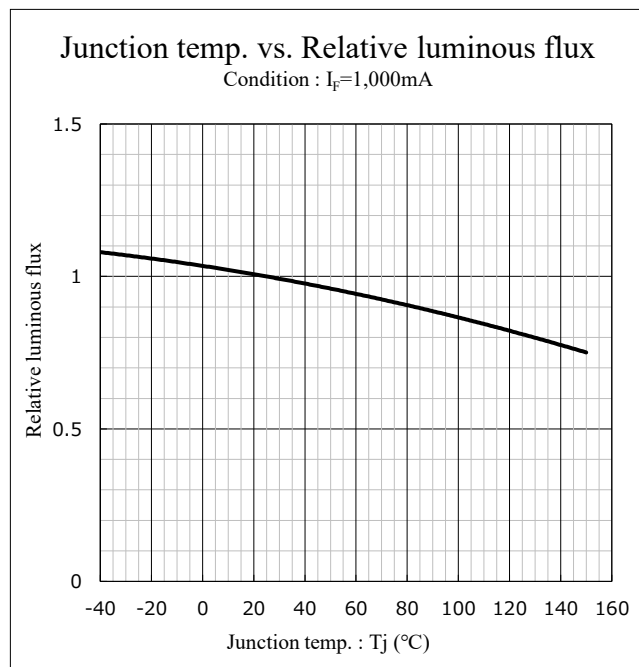
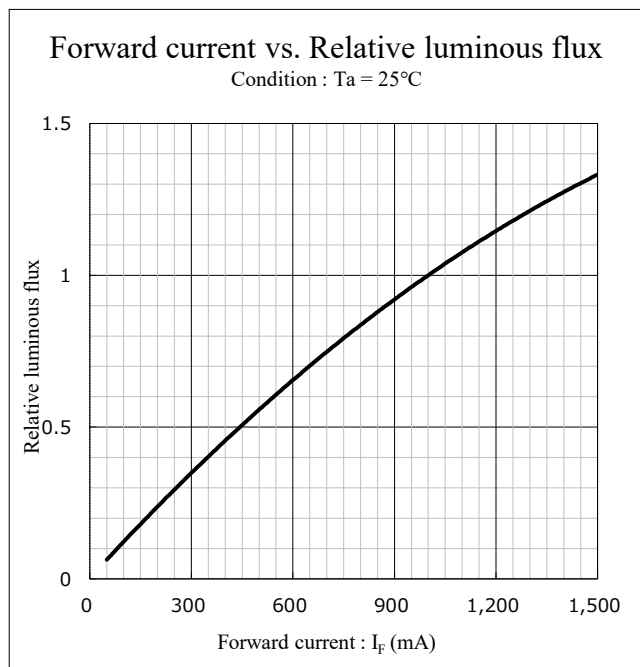
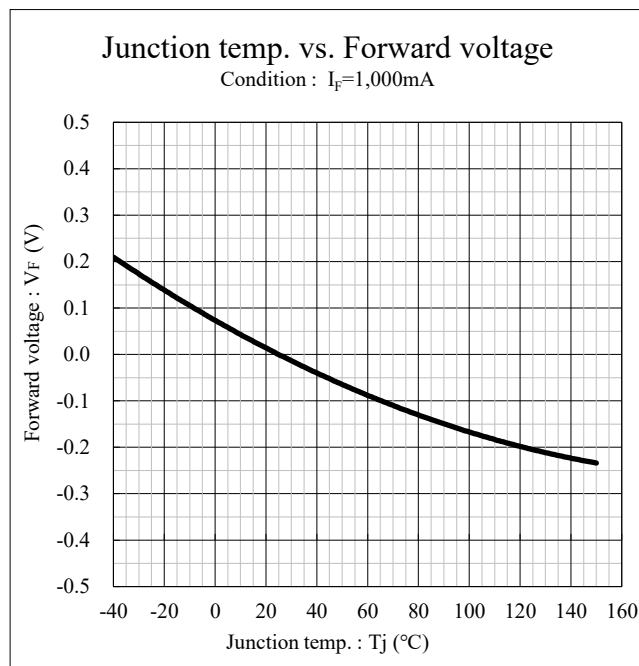
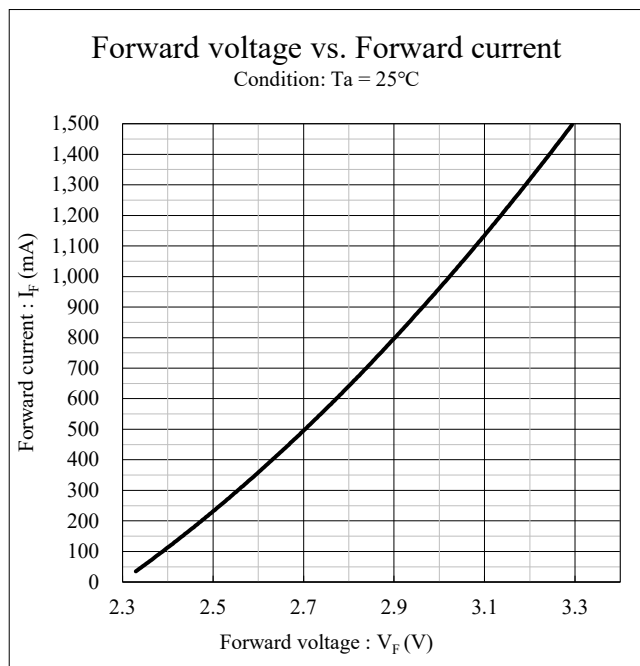

# Technical Data

# HMDWTJA

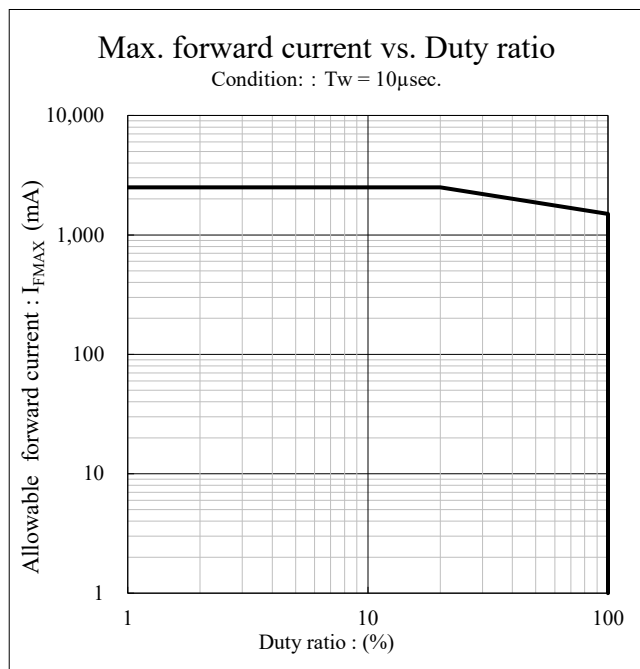
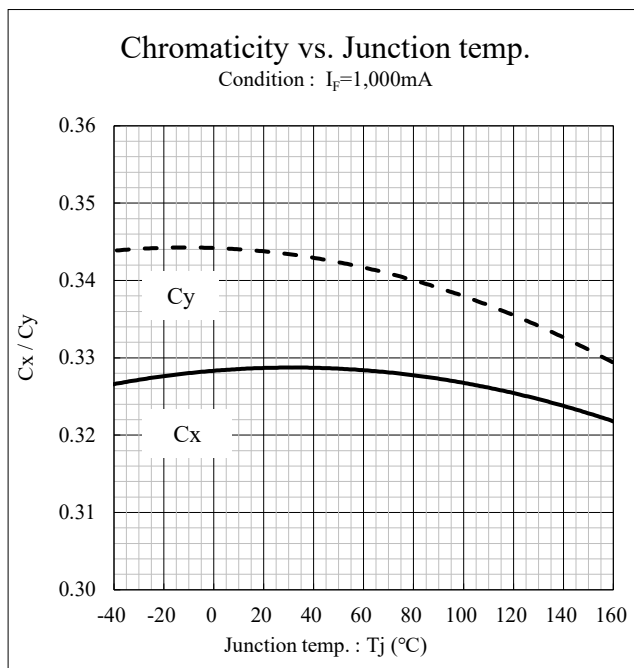
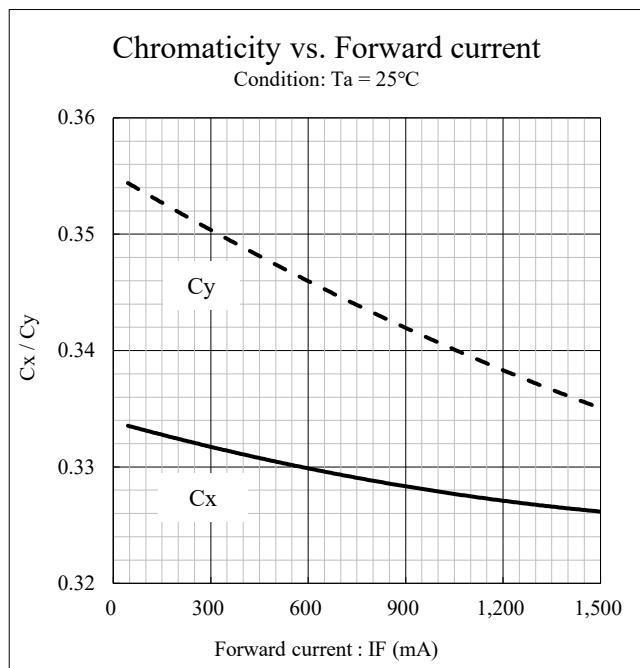

## Soldering condition

HMDWTJA

### 【Soldering Precaution】

(acc.to EIAJ-4701/300)

1. Heat stress during soldering will influence the reliability of LEDs, however that effect will vary on heating method. Also, if components of varying shape are soldered together, it is recommended to set the soldering pad temperature according to the component most vulnerable to heat (e.g., surface mount LED).
2. LED parts including the resin are not stable immediately after soldering ( when they are not at room temperature), any mechanical stress may cause damage to the product. Please avoid such stress after soldering, especially stacking of the boards which may cause the boards to warp and any other types of friction with hard materials.
3. Recommended temperature profile for the reflow soldering is listed as the temperature of the resin surface. Temperature distribution varies on heating method, PCB material, other components in the assembly, and mounting density. Please do not repeat the heating process in reflow process more than 2 times.
4. The use of metal substrates can cause problems with solder cracks due to the high stresses placed on the solder joints by thermal shock. Before using a metal substrate, please make sure that it has been thoroughly tested before use. A low stress base material is recommended for the insulation layer of the metal substrate.

This product is equivalent to MSL 2 according to IPC/JEDEC J-STD-020F.

### 【Recommended Reflow Soldering Condition】

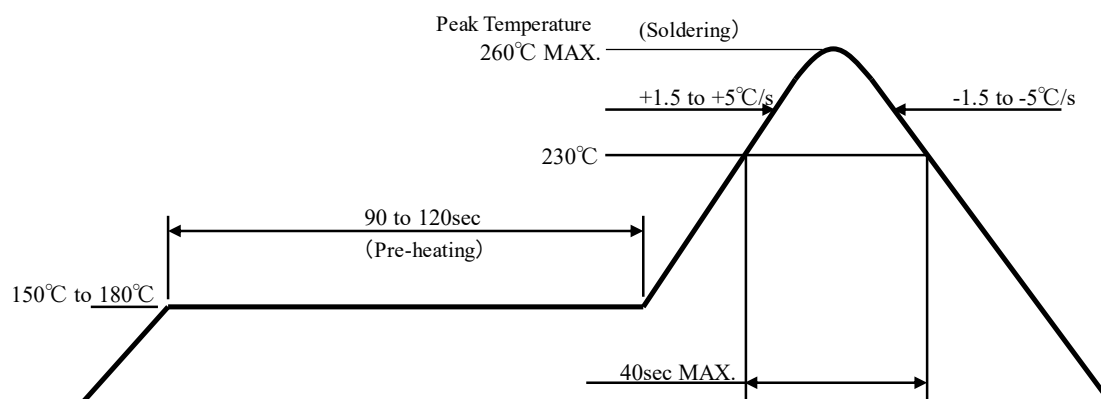

Note 1 Temperature profile for the reflow should be set to the surface temperature of resin which is on the top of LED. This should be the maximum temperature for soldering. Lowering the heating temperature and decreasing heating time is very effective in achieving higher reliability.

Note 2 The reflow soldering process should be done up to 2 times Max. When second process is performed, interval between first and second process should be as short as possible to prevent absorption of moisture to resin of LED. The second soldering process should not be done until LEDs have returned to room temperature (by nature-cooling) after first soldering process.

## Soldering condition

HMDWTJA

5. This product is not guaranteed for hand soldering or dip (wave/flow) soldering.
6. We will recommend isopropyl alcohol as a solvent used for cleaning. Some chemicals, including Freon substitute detergent could corrode the lens or the casing surface, which cause discoloration, cloud, crack and so on. Please review the reference chart below for cleaning. If water is used to clean (including the final cleaning process), please use pure water (not tap water), and completely dry the component before using. We do not recommend ultrasonic cleaning.

Cleaning agents	Recommended / Not recommended
Isopropyl Alcohol	✓ Recommended
Ethyl Alcohol	✓ Recommended
Pure Water	✓ Recommended
Trichloroethylene	x Not recommended
Chloroethene	x Not recommended
Acetone	x Not recommended
Thinner	x Not recommended
Hexane	x Not recommended

# Handling precautions

HMDWTJA

## 【For electrostatic discharge (ESD)】

LED with an InGaN die is sensitive to voltage surges generated by On/Off status change and friction with synthetic materials, which may cause severe damage to the die or undermine its reliability. Damaged products may experience conditions such as extremely high reverse voltage, decrease of forward rise voltage, deterioration in optical characteristics.

Stanley InGaN products are packed with anti-static components. However, following precautions must be taken into account upon product shipment.

### 1. Electrification/static electricity protection

In order to avoid product (die) damage from static electricity caused by unprotected handling by operator and other charged materials coming in contact with the product, Stanley recommends taking the following precautions.

- ① Do not place electrified non-conductive materials near the LED product.  
Avoid LED products from coming into contact with metallic materials.( Should the metallic material be electrified , the sudden surge voltage will most likely damage the product.)
- ② Avoid a working process which may cause the LED product to rub against other materials.
- ③ Install ground wires for any equipment, where they can be installed, with measures to avoid static electricity surges.
- ④ Prepare a ESD protective area by placing a Conductive Mattress (1MΩ MAX.) and Ionizer to remove any static electricity.
- ⑤ Operators should wear a protective wrist-strap.
- ⑥ Operators should wear conductive work-clothes and shoes.
- ⑦ To handle the products directly, Stanley recommends the use of ceramic, and not metallic, tweezers.

### 2. Working environment

- ① A dry environment is more likely to cause static electricity. Although a dry environment is ideal for storage state of LED products, Stanley recommends an environment with approximately 50% humidity after the soldering process.
- ② Recommended static electricity level in the working environment is less than 150V, which is the same value as Integrated Circuits (which are sensitive to static electricity).

## Handling precautions

HMDWTJA

### 【Other precautions】

1. The products are designed to achieve higher performance reliability, however, they can be influenced by usage conditions.
2. Absolute maximum ratings are set to prevent LED products from breaking due to extreme stress (temperature, current, voltage, etc.). These ratings must never be overrun even for a moment.
3. To achieve the highest performance reliability, it is necessary to take into account, factors such as forward voltage adjusted to the usage temperature condition, derating of the power consumption, and other variable factors.
4. Please insert straight protective resistors into the circuit in order to stabilize LED operation and to prevent the device from overheating.
5. Please avoid to use the products with materials and products that contain sulfur and chlorine element because the reliability may be decreased. Please keep in desicator regardless of before or after mounting not to be affected by corrosive gas when keeping products. Also please make sure if there is any gas which occur in surrounding area or enter from outside when using products.
6. This product usually has sufficient resistance to sulfurization; however, if used in the same environment as materials containing large amounts of sulfur (including packaging materials), it may cause defects such as LED not illuminating due to sulfide corrosion. Please avoid exposing this product to materials that contain high concentrations of sulfur.
7. Although this product has passed the sulfurization test recommended by major car manufacturers, when using materials containing sulfur components on this product or the actual unit where this product is mounted, there is a possibility that the environment will be beyond the test's expectations. Please check the impact of the sulfur components before use.  
Examples of materials containing sulfur components: gaskets, rubber packaging materials, grease, cardboard boxes, rubber (such as vulcanized rubber), sponges, etc. In addition, because there is a possibility of corrosion due to unexpected sources of sulfur (from surrounding environment or materials), even it does not contain the above materials we nevertheless recommend that you check the actual unit where this product is mounted, as well as the operating environment.
8. Please avoid to stick foreign material because molding resin in the products has adhesiveness.
9. When used at high temperature, it may cause a short circuit due to ion migration in solder flux. Please carry out a thorough advance verification, check for any problems and then use.
10. Please check the actual performance in the assembly because the specification sheets are described for LED only.
11. Supersonic wave welding is not recommended because wire open circuit may occurs.  
(ex) Bonding outer lens to this product or housing.
12. The products are designed to perform without failure in the recommended usage conditions. However, please take the necessary precautions to prevent fire, injury, and other damages from these unexpected failures.
13. The products are manufactured to be used for ordinary electronic equipment. Please contact our sales staff in advance when exceptional quality and reliability are required, when the failure or malfunction of the products might directly jeopardize life or health ( such as for airplanes, aerospace, transport equipments, medical applications, nuclear reactor control systems and so on).

## Handling precautions

HMDWTJA

### 【Other precautions】

14. Adjacent parts may deteriorate due to the heat generated from the LES or the condensed light from the lens, etc. Product design that considers the effects of heat and light is recommended.
15. Concerning eye safety, according to the international Electrical Commission (IES) standard IED62471 published in 2006 about photobiological safety of lamps and lamp systems, almost all STANLEY ELECTRIC Co., LTD. LEDs can be classified as belonging to either "Exempt group" or "Risk group1"(low risk); however high-power LEDs that emit light containing blue wavelengths, may be classified as belonging to "Risk group2"(moderate risk). Please refrain from looking directly at the light source of LEDs at high output current, when using multiple LEDs at the same time or when focusing the light with optical instruments, as these actions might harm your vision.
16. The formal specification sheets should be exchanged and signed by both parties.

# Handling precautions

HMDWTJA

## 【Handling precautions for product mounting】

<Recommendation>

1. Picking up point with nozzle : Pick up point : Emission area. (Refer to below figure)

Please pick up by light-emitting part only, because molding resin in this products is low-hardness. Nozzle contact with parts other than emission area may cause damage to the product.

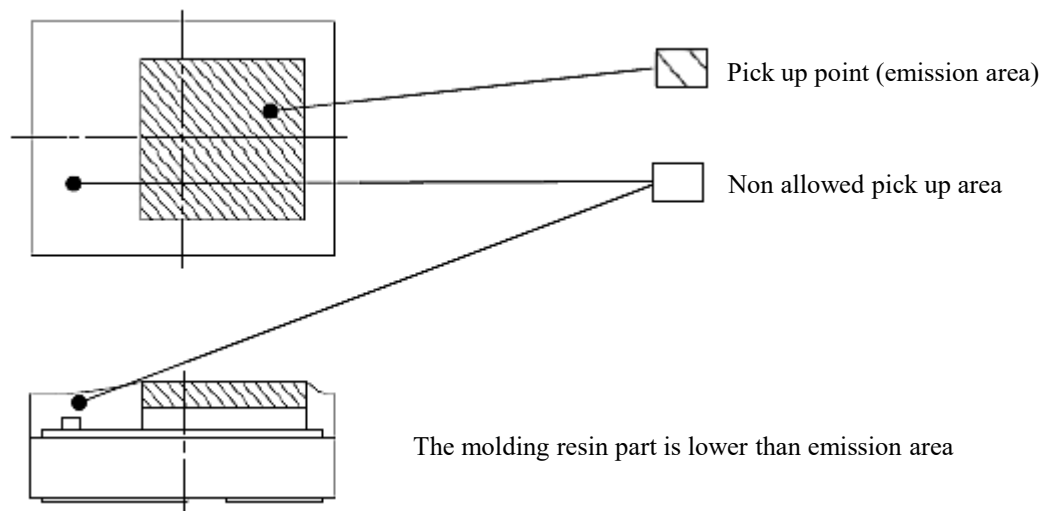

2. Load: Less than 3N

3. The recommended inner diameter for the nozzle is  $\phi 0.4\text{mm}$ , and  $\phi 0.8\text{mm}$  for the outer diameter.

Please adjust the load, the pick up point, the nozzle diameter etc. before mounting, because the overload may cause the breakage of the emission area.

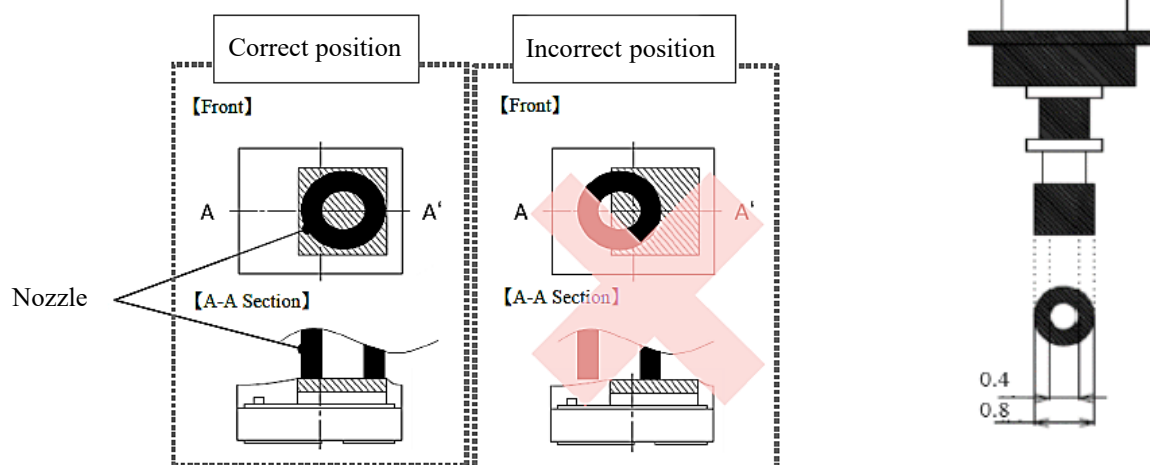

## Handling precautions

HMDWTJA

### 【Handling precautions for product mounting】

4. The recommended value for mounting deviation is 50 $\mu$ m or less. It may not self-alignment any further.  
Please carry out a thorough advance verification, check for any problems and then use.

### 【Manual handling precautions】

Using vacuum tweezers is recommended for manual handling, in the trial manufactures for example.  
Please handle products so as not to touch the resin area.

### <Recommendation>

Handling with vacuum tweezers

Pick up point : Light-emitting part. (Refer to below figure)

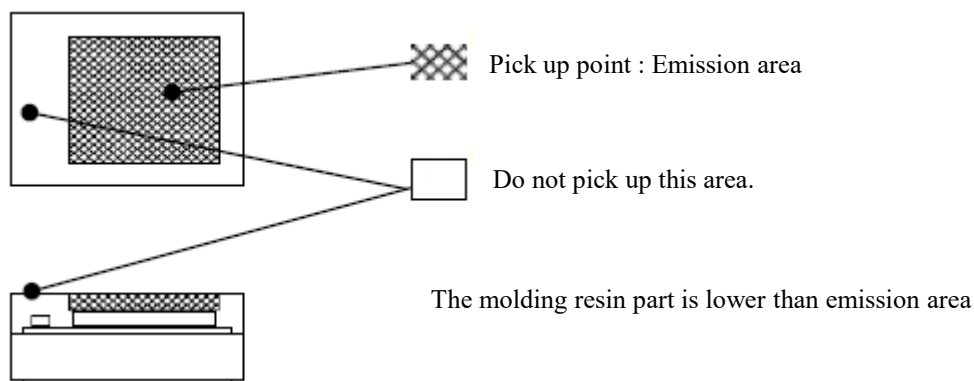

Please pick up by specified parts only, because molding resin in this products is low-hardness.  
Contact to parts other than specified parts may cause damage to the product.

## Packaging specifications

HMDWTJA

This product is baked (moisture removal) before packaging, and is shipped in moisture-proof packaging (as shown below) to minimize moisture absorption during transportation and storage. However, with regard to storing the products, Stanley recommends the use of dry-box under the following conditions is recommended. Moisture-proof bag as the packaging is made of anti-static material but packaging box is not.

### 【Recommended storage condition / products warranty period】

Temperature	+5 to 30°C
Humidity	Under 60%

In the case of the package unopened, please use within 12 months 【Recommended storage condition】. Please avoid rapid transition from low temp. condition to high temp. condition and storage in corroding and dusty environment.

### 【Time elapsed after package opening】

This product is equivalent to IPC/JEDEC J-STD-020F MSL 2.

The package should not be opened until immediately prior to its use.  
If any components should remain after their use, please seal the package and store them under the conditions described in the 【 Recommended Storage Condition 】.

# Packaging specifications

HMDWTJA

## 【Moisture-proof packaging specification】

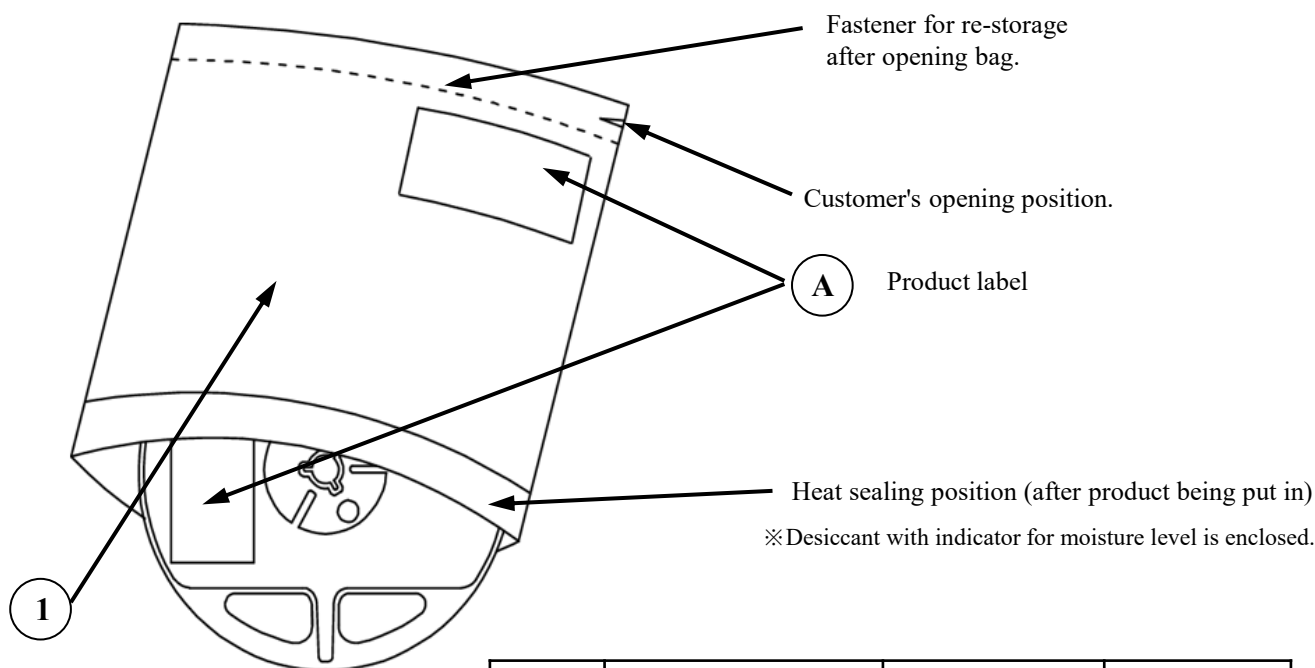

No.	Part name	Material	Remarks
①	Moisture-proof bag with Aluminum layer	PET+Al+PE	with ESD protection

## 【Flow chart-package opening to mounting】

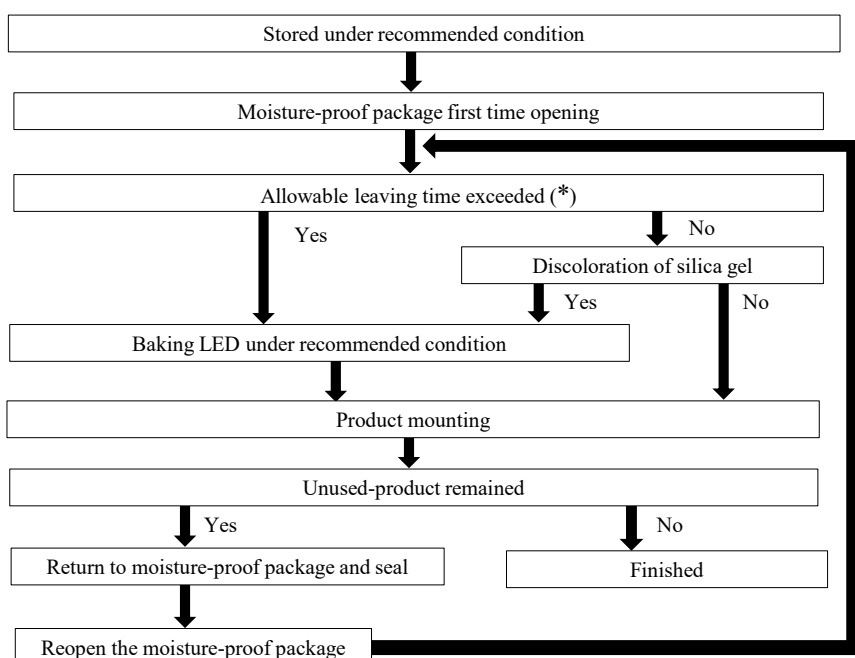

Allowable leaving time means the maximum allowable leaving time after opening package, which depends on each LED type. The allowable leaving time should be calculated from the first opening of package to the time when soldering process is finished. When judging if the allowable leaving time has exceeded or not, please subtract the soldering time. The allowable leaving time after reopening should be calculated from the first opening of package, or from the time when baking process is finished.

# Packaging specifications

HMDWTJA

## 【 Packing box 】

(RoHS / ELV compliant)

Box type	Outline dimension L × W × H (mm)	Capacity of the box
Type A	280 × 265 × 45	3 reels
Type B	310 × 235 × 265	15 reels
Type C	440 × 310 × 265	30 reels
Type D	305 × 270 × 65	3 reels
Type E	370 × 280 × 270	30 reels
Type F	530 × 380 × 270	60 reels

The above measurements are reference values.

The box is selected out of the above table by shipping quantity.

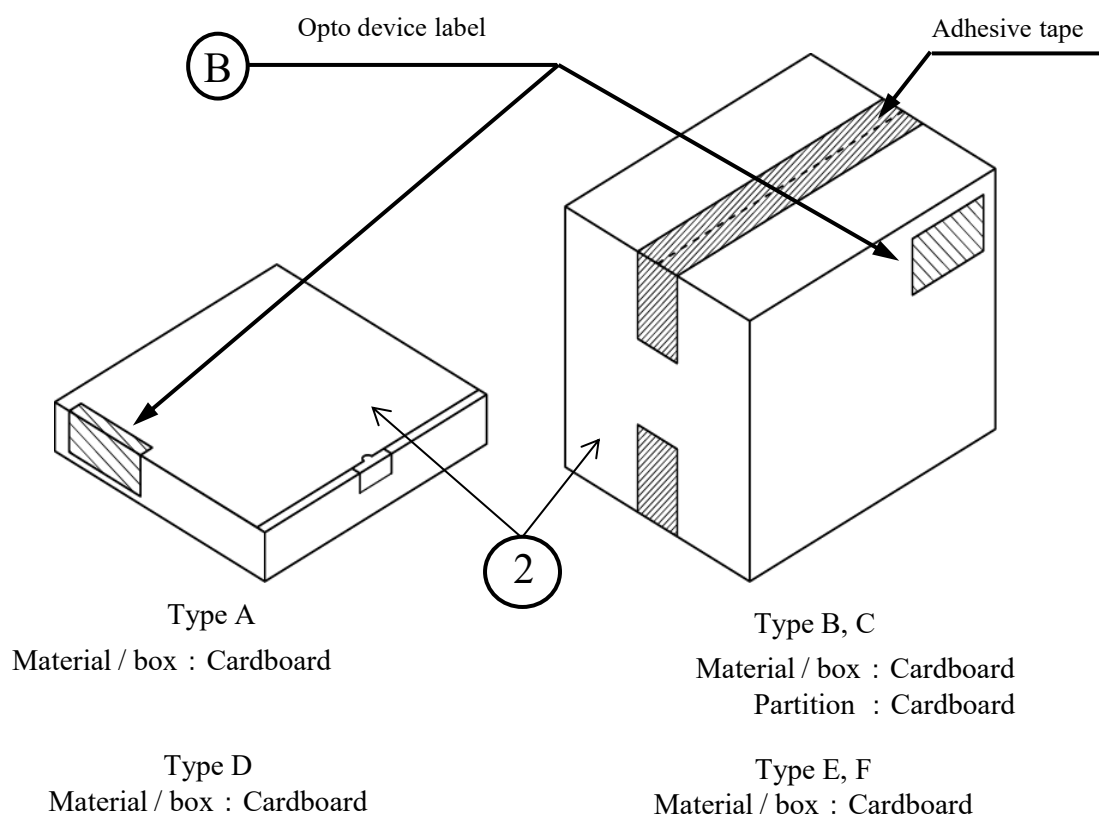

No.	Part name	Material	Remarks
②	Packing box	Corrugated Cardboard	without ESD protection

## Packaging specifications

HMDWTJA

### 【Label specification】

(acc.to ISO-IEC16388)

#### A Product label

- A. Parts number
- B. Bar-code for parts number
- C. Parts code (In-house identification code for each parts number)
- D. Packed parts quantity
- E. Bar-code for packed parts quantity
- F. Lot number & rank  
(refer to Lot number notational system for details)
- G. Bar-code for lot number & rank
- H. MSL

#### B Opto device label

- A. Customer name
- B. Parts type
- C. Parts code
- D. Parts number
- E. Packed parts quantity
- F. Carton number
- G. Shipping date
- H. Bar-code for In-house identification number

<Remarks> Bar-code font : acc.to ISO-IEC16388

## Taping and reel specifications

HMDWTJA

(acc.to IEC60286-3)

## 【Appearance】

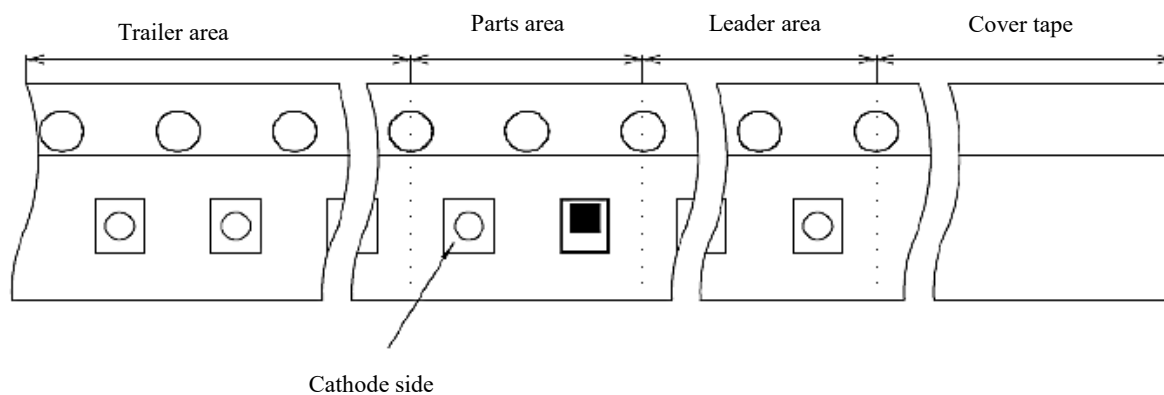

## Note

The form in which the cathode side comes to the opposite side of the extraction direction is called 【-TF】.

Items		Specifications	Remarks
Leader area	Cover-tape	Cover-tape shall be longer than <b>300mm</b> without carrier-tape	The end of cover-tape shall be held with adhesive tape.
	Carrier-tape	Empty pocket shall be more than <b>25 pieces</b> .	Please refer to the above figure for Taping & reel orientation .
Trailer area		Empty pocket shall be more than <b>40 pieces</b> .	The end of taping shall be inserted into a slit of the hub.

## Taping and reel specifications

HMDWTJA

(acc.to JIS-C0806-03)

### 【Qty. per reel】

3,000parts/reel

Minimum Qty. per reel might be 500 parts when getting less than 3,000 parts.

In such case, parts of 100-unit-qty. shall be packed in a reel and the qty. shall be identified on the label

### 【Mechanical strength】

Cover-tape adhesive strength shall be 0.1 to 1.3N ( An angle between carrier-tape and cover-tape shall be 170 deg. ).

Both tapes shall be so sealed that the contained parts will not come out from the tape when it is bent at a radius of 15mm.

### 【Others】

Reversed-orientation, Up-side down placing, side placing and out of spec. parts mix shall not be held.

Empty Pocket per reel is assumed until 1 piece.

# Taping and reel specifications

(acc.to JIS-C0806-03)

HMDWTJA

Unit: mm

## 【Taping dimensions】

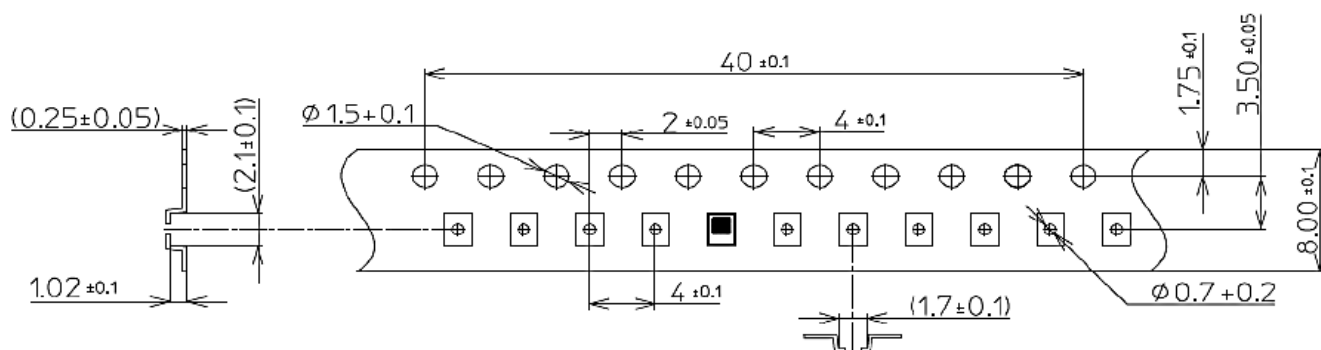

## 【Reel dimensions】

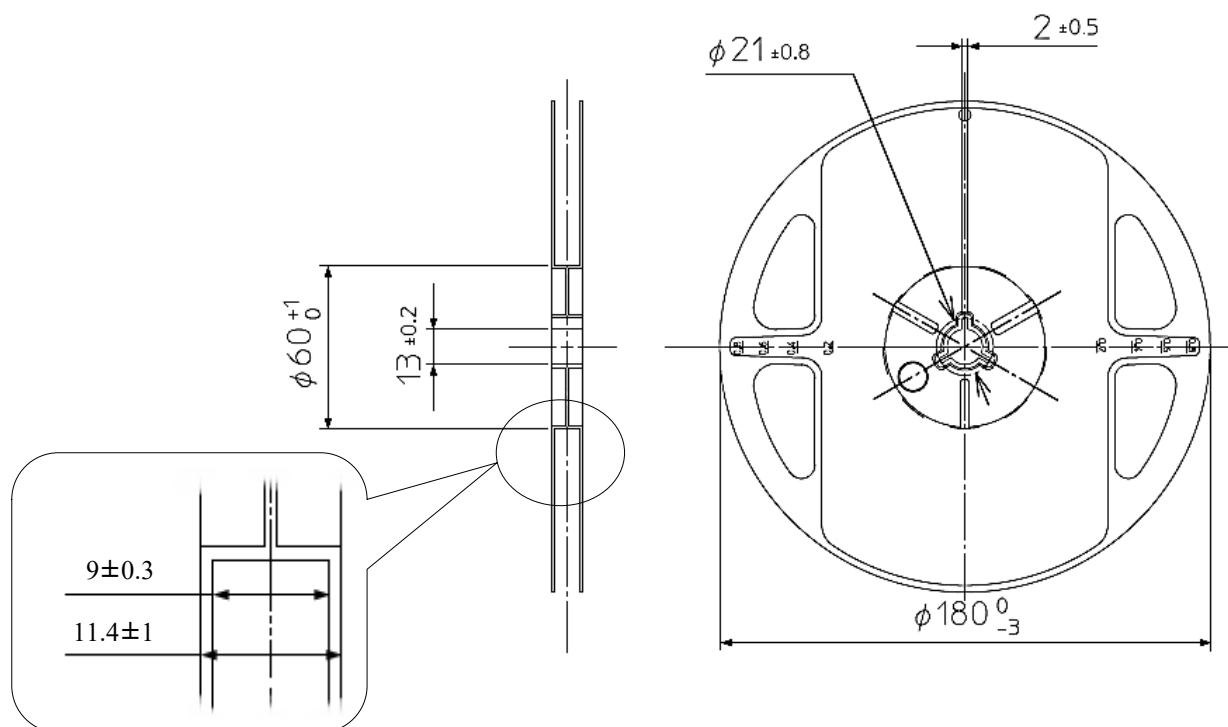

## Lot number notational system

HMDWTJA

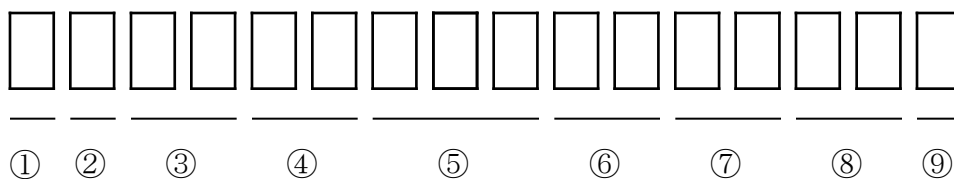

- ① - 1digit : Production location (mark identify alphabet)
- ② - 1digit : Production year (The last digit of production year 2025→5, 2026→6, 2027→7, 2028→8 …)
- ③ - 2digits : Production month (Jan. to Sep. , should be 01,02,03 …)
- ④ - 2digits : Production date
- ⑤ - 3digits : Serial number
- ⑥ - 2digits : Tape and reel following number
- ⑦ - 2digits : Total power rank.  
(If total power rank is 1 digit, "-" shall be dashed on the place for the second digit.  
If there is no identified rank, "- -" is used to indicate.)
- ⑧ - 2digits : Color / chromaticity rank  
(If color / chromaticity rank is 1 digit, "-" shall be dashed on the place for the second digit.  
If there is no identified intensity rank, "- -" is used to indicate.)
- ⑨ - 1digit : VF rank (If rank is not defined, "-" is described.)

## Compliance with RoHS / ELV

HMDWTJA

This product is in compliance with RoHS / ELV.

Prohibition substance and it's criteria value of RoHS / ELV are as follows.

- RoHS instruction ... Refer to following 1 to 10.
- ELV instruction ... Refer to following 1 to 4.

2011/65/EU, (EU)2015/863

No.	Substance group name	Maximum permissible concentration value
1	Lead and its compounds	1,000ppm (0.1%)
2	Cadmium and its compounds	100ppm (0.01%)
3	Mercury and its compounds	1,000ppm (0.1%)
4	Hexavalent chromium compounds	1,000ppm (0.1%)
5	PBB : Polybrominated Biphenyls	1,000ppm (0.1%)
6	PBDE : Polybrominated Biphenyl Ethers	1,000ppm (0.1%)
7	DEHP : Bis (2-ethylhexyl) phthalate	1,000ppm (0.1%)
8	BBP : Butyl benzyl phthalate	1,000ppm (0.1%)
9	DBP : Dibutyl phthalate	1,000ppm (0.1%)
10	DIBP : Diisobutyl phthalate	1,000ppm (0.1%)

# Reliability Test

HMDWTJA

## 1. Reliability testing result

No.	Test item	Test condition	Duration	Failure
1	Wet high temperature operating life 1	Ta=85°C 85% I <sub>F</sub> =Max 30min ON/OFF	1,000hr	0/26p
2	Wet High temperature operating life 2	Ta=85°C 85% I <sub>F</sub> =Min	1,000hr	0/26p
3	High temperature operating life	T <sub>j</sub> =150°C I <sub>F</sub> =Max	1,000hr	0/26p
4	Pulsed life	Ta=55°C Pulse width: 100μS Duty3% I <sub>FPulse</sub> =Max	1,000hr	0/26p
5	temperature cycling 1	-40°C (15min) to 135°C (15min)	1,000cyc	0/26p
6	Power temperature cycling 2	-40°C (15min) to 85°C (15min) T <sub>j</sub> =150°C 5min ON/OFF	1,000cyc	0/26p
7	Vibration variable frequency	200m/s <sup>2</sup> or 1.5mm amplitude 20Hz to 2,000Hz to 20Hz	XYZ each 4cyc	0/10p
8	Mechanical shock	15,000m/s <sup>2</sup> 0.5ms 6 directions	Each 5 times	0/10p
9	Dew	20-10°C/0.25hr→10°C/1hr→10-80°C/3.5hr,95-100%→ 80-75°C→75°C/0.5hr→75-20°C/1.25hr 6.5hr/cycle I <sub>F</sub> =Min For details, refer to the AEC-Q102-001 profile.	10cyc	0/26p
10	Electrostatic Discharge Human Body Model	C=100pF R2=1.5kΩ ±2,000Vstart	Each 3 times	0/10p
11	Resistance to solder heat	Moisture soak : JEDEC Level2 Preheating : 150 to 180°C 120sec Max. Soldering : 260°C Peak	5 times	0/10p
12	Solderability	Moisture soak : 105°C, 100%, 4hr Pb free: 245°C 5sec (Solder adhesion rate of 95% or more)	1 time	0/10p
13	Gas exposure test (Hydrogen sulphide)	40°C, 90%, 15ppm	336hr	0/26p
14	Gas exposure test (Flowing mixed gas)	Mixed Gas : 25°C, 75%, H <sub>2</sub> S 0.01ppm, SO <sub>2</sub> 0.2ppm, NO <sub>2</sub> 0.2ppm, Cl <sub>2</sub> 0.01ppm	500hr	0/26p
15	Board flex	Mount in the longitudinal direction of the test PWB and apply a load from the back of the PWB until the PWB deflects by 3 mm.	1 time	0/10p
16	Temperature cycling 3	-40°C (30min) to 85°C (30min)	3,000cyc	0/26p

# Reliability Testing Result

HMDWTJA

## Electrostatic Discharge Human Body Model Test Profile

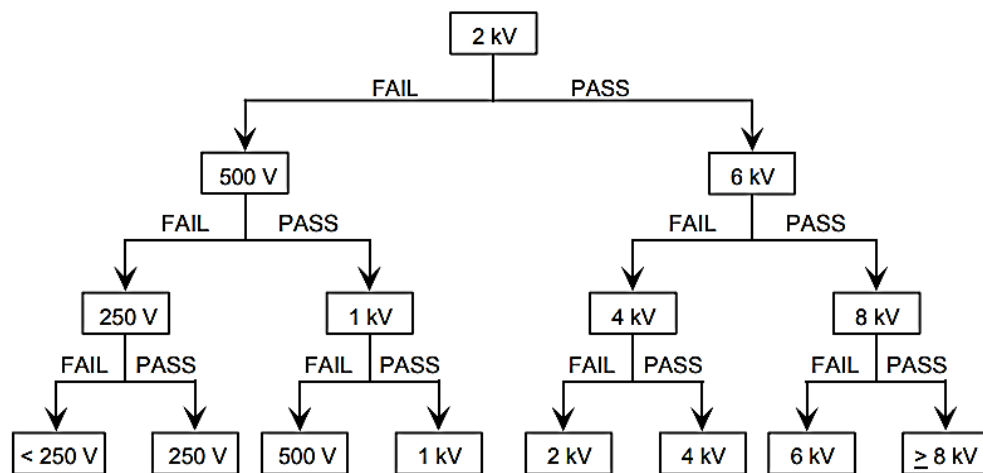

Note 1: Classify the components according to the highest ESD voltage level survived during ESD testing.

## 2. Failure criteria

Item	Symbol	Condition	Failure criteria
Luminous intensity	$I_v$	$I_F=1,000\text{mA}$ $T_a=25^\circ\text{C}$	Measured value $<$ initial value $\times 0.8$ , measured value $\geq$ initial value $\times 1.2$
Chromaticity	ccx, ccy	$I_F=1,000\text{mA}$ $T_a=25^\circ\text{C}$	Measured value $<$ initial value $- 0.01$ , measured value $>$ initial value $+0.01$
Forward voltage	$V_F$	$I_F=1,000\text{mA}$ $T_a=25^\circ\text{C}$	Measured value $<$ initial value $\times 0.9$ , measured value $\geq$ initial value $\times 1.1$
External appearance	—	—	Significant discoloration, deformation and cracking

## Special notice to customers using the products and technical information shown in this data sheet

- 1) The technical information shown in the data sheets are limited to the typical characteristics and circuit examples of the referenced products. It does not constitute the warranting of industrial property nor the granting of any license.
- 2) For the purpose of product improvement, the specifications, characteristics and technical data described in the data sheets are subject to change without prior notice. Therefore it is recommended that the most updated specifications be used in your design.
- 3) When using the products described in the data sheets, please adhere to the maximum ratings for operating voltage, heat dissipation characteristics, and other precautions for use. We are not responsible for any damage which may occur if these specifications are exceeded.
- 4) The products that have been described to this catalog are manufactured so that they will be used for the electrical instrument of the benchmark (OA equipment, telecommunications equipment, AV machine, home appliance and measuring instrument).  
The application of aircrafts, space borne application, medical equipment and nuclear power control equipment, etc. needs a high reliability and safety, and the breakdown and the wrong operation might influence the life or the human body. Please consult us beforehand if you plan to use our product for the usages of aircrafts, space borne application, transportation equipment, medical equipment and nuclear power control equipment, etc. except OA equipment, telecommunications equipment, AV machine, home appliance and measuring instrument.
- 5) In order to export the products or technologies described in this data sheet which are under the “Foreign Exchange and Foreign Trade Control Law,” it is necessary to first obtain an export permit from the Japanese government.
- 6) No part of this data sheet may be reprinted or reproduced without prior written permission from Stanley Electric Co., Ltd.
- 7) The most updated edition of this data sheet can be obtained from the address below:  
en <https://www.stanley-electric.com/en/products/>  
cn <https://www.stanley-electric.cn/cn/products/>