

Data sheet

Part number : BXFW115MCR-300-TR

Under
development



2011/65/EU, (EU)2015/863
10 Substances regulation compliant

Package	SMD Top view mini package, White color emitting LED Outer dimension 1.5 x 1.5 x 1.15mm (L x W x H)
Product features	<ul style="list-style-type: none"> • Bat-wing radiation pattern with wide spatial distribution angle as shown below • AEC-Q102 compliant • Wide color gamut (Blue chip + Red and Green phosphor) • High uniformity with Bat-Wing Distribution • Chromaticity coordinates $x = 0.2770$ $y = 0.2600$ @30mA • Lead-free soldering compliant • RoHS:2011/65/EU, (EU)2015/863 compliant

Recommended applications

- Direct-lit backlight for LCD of automotive interior

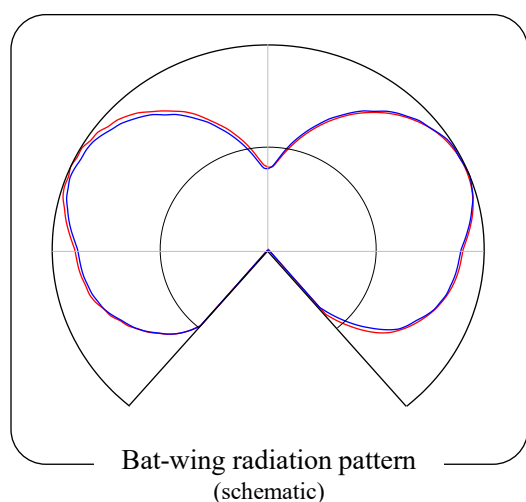

Outline dimensions

BXFW115MCR-300-TR

Unit : mm
Tolerance : ±0.1

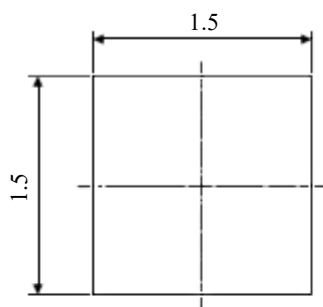

Top view

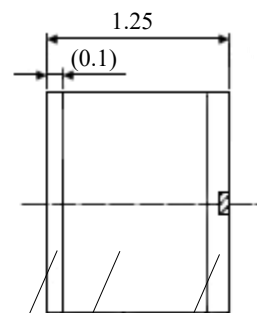

Side view

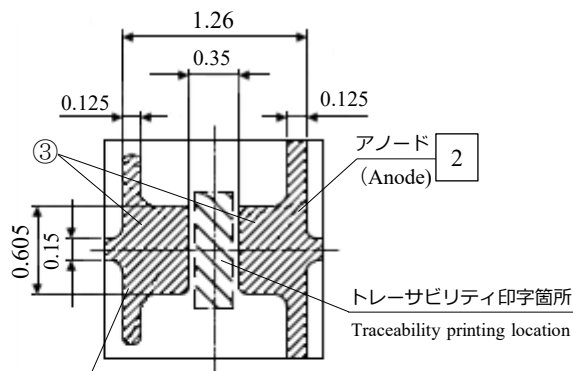

Bottom view

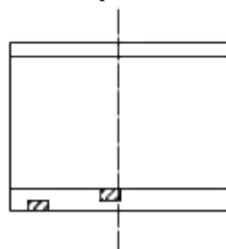

Inside circuit

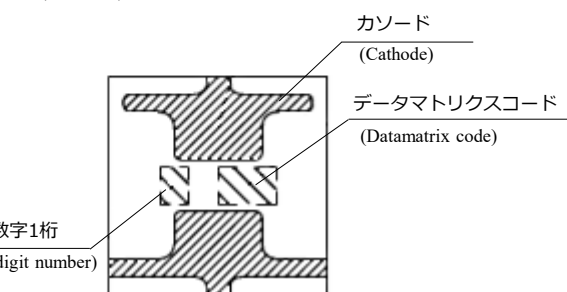
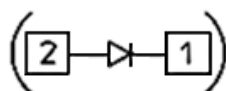

トレーサビリティ印字内容 / Traceability Print Content

記号 Symbol	部品名 Part name	数量 QTY.	備考 Remarks
-	LED素子 LED die	1	InGaN
①	封止樹脂 Mold resin	-	シリコン樹脂 Silicone resin
②	基材 Substrate	-	エポキシ樹脂+酸化チタン Epoxy resin+TiO ₂
③	電極 Electrode	-	銅 (金めっき) Copper (Gold plating)
④	反射層 Reflective layer	-	シリコン樹脂+酸化チタン Silicone resin+TiO ₂

Recommended pad

Unit: mm

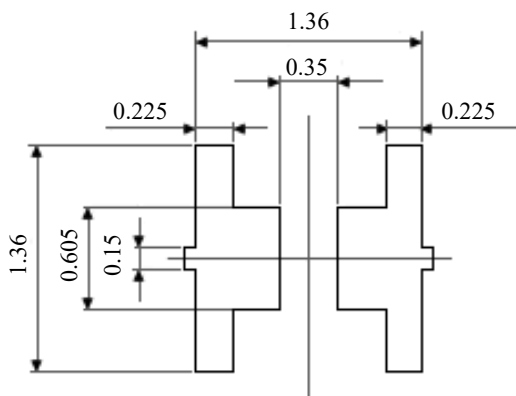

Note 1 The burr size isn't contained in the size of the product.

Note 2 Please note no short-circuit when the wiring pattern is arranged between the soldering attachment pad.

Specifications

BXFW115MCR-300-TR

【製品の概要 / Product overview】

素子材料 Die material	InGaN
発光色 Emitting color	白色(青色素子+蛍光体1+蛍光体2) White (Blue chip + Phosphor1 + Phosphor2)
発光部樹脂色 Resin color 【Emitting area】	淡黄色 Diffused pale yellow

【絶対最大定格 / Absolute Maximum Ratings】

(Ta=25°C)

項目 Item	記号 Symbol	最大定格 Maximum ratings	単位 Units
許容損失 Power dissipation	P_d	650	mW
順電流 Forward current	I_F	100	mA
パルス順電流 【(5ms),1/4duty】 Repetitive peak forward current "(5ms),1/4duty"	I_{FRM}	120	mA
動作温度 Operating temperature	T_{opr}	-40 to +105	°C
保存温度 Storage temperature	T_{stg}	-40 to +120	°C
静電耐圧 【HBM】 Electrostatic discharge threshold "HBM"	ESD	4,000	V
はんだ付け温度 【リフロー】 Soldering temperature "Reflow soldering"	T_{sld}	260	°C
ジャンクション温度 Junction temperature	T_j	125	°C

Note 3

Note 3 ESD testing method : Human Body Model(HBM) /Acc. to ANSI/ESDA/JEDEC JS-001

【Thermal characteristics】

項目 Item	記号 Symbol	標準値 Typ.	単位 Units
熱抵抗【ジャンクション-はんだ付け位置】 Thermal resistance 【Junction - solder point】	$R_{th(j-s)}$	20	°C/W

Specifications

BXFW115MCR-300-TR

【Electro-optical characteristics】

項目 Item	記号 Symbol	条件 Conditions	最小値 Min.	標準値 Typ.	最大値 Max.	単位 Units	
順電圧 Forward voltage	V_F	$I_F = 30\text{mA}$	5.2	5.7	6.2	V	Note 4
逆電流 Reverse current	I_R	$V_R = 10\text{V}$	-	-	1.0	μA	
光束 Luminous flux	Φ_V	$I_F = 30\text{mA}$	15.5	20.1	26.1	lm	Note 5
色度座標 Chromaticity coordinates	x	$I_F = 30\text{mA}$	-	0.2770	-		Note 5,6
	y	$I_F = 30\text{mA}$	-	0.2600	-		
指向半値角 2 θ 1/2 Half intensity angle 2 θ 1/2	$\Delta\theta_x$	$I_F = 30\text{mA}$	-	(290)	-	deg.	Note 7
指向半値角 2 θ 1/2 Half intensity angle 2 θ 1/2	$\Delta\theta_y$	$I_F = 30\text{mA}$	-	(290)	-	deg.	
ピーク波長(青色素子) Peak wavelength (Blue chip)	λ_p	$I_F = 30\text{mA}$	444	-	454	nm	
ピーク波長(蛍光体1) Peak wavelength (Phosphor 1)	λ_p	$I_F = 30\text{mA}$	-	540	-	nm	
ピーク波長(蛍光体2) Peak wavelength (Phosphor 2)	λ_p	$I_F = 30\text{mA}$	-	632	-	nm	

Note 4 Tolerance $\pm 0.1\text{V}$

Note 5 Please refer to the attached sheets, each sorting chart

Note 6 Chromaticity coordinates ; x and y according to CIE1931

Note 7 Viewing angle at 50% I_V 【Sorting chart for Luminous flux, Φ_V 】

LEDs shall be sorted out into following chart and each rank parts shall be packed separately when shipping.

ランク Rank	光束 Luminous flux Φ_V (lm)		条件 Conditions	
	最小値 Min.	最大値 Max.		
BF	15.5	16.9	$I_F = 30\text{mA}$ $T_a = 25^\circ\text{C}$	Note 8
BG	16.9	18.4		
BH	18.4	20.1		
BJ	20.1	21.9		
BK	21.9	23.9		
BL	23.9	26.1		

Note 8 Tolerance : each rank $\pm 7\%$

Specifications

【Sorting chart for Peak wavelength, λ_p 】

LEDs shall be sorted out into following chart and each rank parts shall be packed separately when shipping.

ランク Rank	ピーク波長 Peak wavelength λ_p (nm)		条件 Conditions
	3	444	
4	446	448	
5	448	450	
6	450	452	
7	452	454	

Note 9

Note 9 Tolerance Each Rank ; $\pm 1\text{nm}$

【Sorting chart for Chromaticity coordinates, x,y 】

LEDs shall be sorted out into following chart and each rank parts shall be packed separately when shipping.

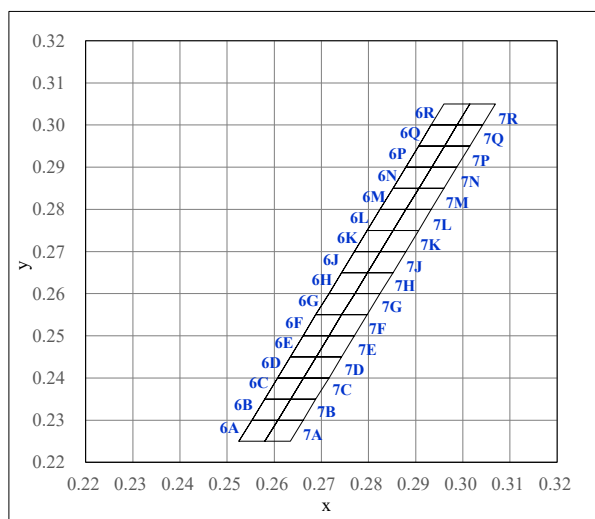
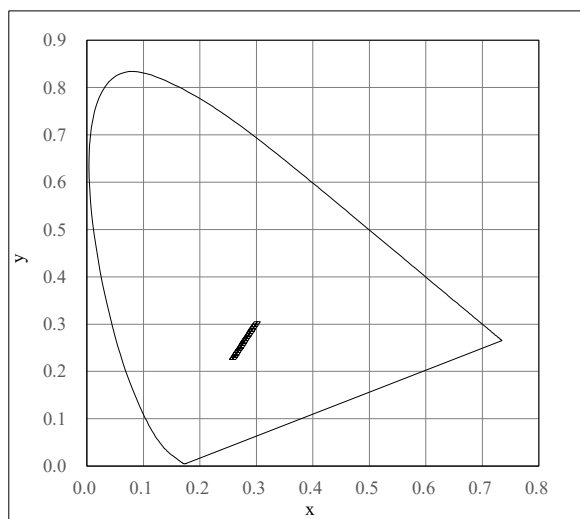

Specifications

BXFW115MCR-300-TR

【Sorting chart for Chromaticity coordinates, x,y】

LEDs shall be sorted out into following chart and each rank parts shall be packed separately when shipping.

(I_F=30mA, Ta=25°C)

λpランク λp Rank	ランク/Rank	Point 1		Point 2		Point 3		Point 4	
		x	y	x	y	x	y	x	y
3	6A	0.2525	0.2250	0.2553	0.2300	0.2608	0.2300	0.2580	0.2250
	6B	0.2553	0.2300	0.2580	0.2350	0.2635	0.2350	0.2608	0.2300
	6C	0.2580	0.2350	0.2607	0.2400	0.2662	0.2400	0.2635	0.2350
	6D	0.2607	0.2400	0.2634	0.2450	0.2689	0.2450	0.2662	0.2400
	6E	0.2634	0.2450	0.2661	0.2500	0.2716	0.2500	0.2689	0.2450
	6F	0.2661	0.2500	0.2688	0.2550	0.2743	0.2550	0.2716	0.2500
	6G	0.2688	0.2550	0.2716	0.2600	0.2771	0.2600	0.2743	0.2550
	6H	0.2716	0.2600	0.2743	0.2650	0.2798	0.2650	0.2771	0.2600
	6J	0.2743	0.2650	0.2770	0.2700	0.2825	0.2700	0.2798	0.2650
	6K	0.2770	0.2700	0.2797	0.2750	0.2852	0.2750	0.2825	0.2700
	6L	0.2797	0.2750	0.2824	0.2800	0.2879	0.2800	0.2852	0.2750
	6M	0.2824	0.2800	0.2852	0.2850	0.2907	0.2850	0.2879	0.2800
	6N	0.2852	0.2850	0.2879	0.2900	0.2934	0.2900	0.2907	0.2850
	6P	0.2879	0.2900	0.2906	0.2950	0.2961	0.2950	0.2934	0.2900
	6Q	0.2906	0.2950	0.2933	0.3000	0.2988	0.3000	0.2961	0.2950
	6R	0.2933	0.3000	0.2960	0.3050	0.3015	0.3050	0.2988	0.3000
	7A	0.2580	0.2250	0.2608	0.2300	0.2661	0.2300	0.2634	0.2250
	7B	0.2608	0.2300	0.2635	0.2350	0.2688	0.2350	0.2661	0.2300
	7C	0.2635	0.2350	0.2662	0.2400	0.2716	0.2400	0.2688	0.2350
	7D	0.2662	0.2400	0.2689	0.2450	0.2743	0.2450	0.2716	0.2400
	7E	0.2689	0.2450	0.2716	0.2500	0.2770	0.2500	0.2743	0.2450
	7F	0.2716	0.2500	0.2743	0.2550	0.2797	0.2550	0.2770	0.2500
	7G	0.2743	0.2550	0.2771	0.2600	0.2824	0.2600	0.2797	0.2550
	7H	0.2771	0.2600	0.2798	0.2650	0.2852	0.2650	0.2824	0.2600
	7J	0.2798	0.2650	0.2825	0.2700	0.2879	0.2700	0.2852	0.2650
	7K	0.2825	0.2700	0.2852	0.2750	0.2906	0.2750	0.2879	0.2700
	7L	0.2852	0.2750	0.2879	0.2800	0.2933	0.2800	0.2906	0.2750
	7M	0.2879	0.2800	0.2907	0.2850	0.2960	0.2850	0.2933	0.2800
	7N	0.2907	0.2850	0.2934	0.2900	0.2987	0.2900	0.2960	0.2850
	7P	0.2934	0.2900	0.2961	0.2950	0.3015	0.2950	0.2987	0.2900
	7Q	0.2961	0.2950	0.2988	0.3000	0.3042	0.3000	0.3015	0.2950
	7R	0.2988	0.3000	0.3015	0.3050	0.3069	0.3050	0.3042	0.3000

Note 10

Note 10 Tolerance each rank : ±0.005

Specifications

BXFW115MCR-300-TR

【Sorting chart for Chromaticity coordinates, x,y】

LEDs shall be sorted out into following chart and each rank parts shall be packed separately when shipping.

(I_F=30mA, Ta=25°C)

λpランク λp Rank	ランク/Rank	Point 1		Point 2		Point 3		Point 4	
		x	y	x	y	x	y	x	y
4	6A	0.2525	0.2250	0.2553	0.2300	0.2608	0.2300	0.2580	0.2250
	6B	0.2553	0.2300	0.2580	0.2350	0.2635	0.2350	0.2608	0.2300
	6C	0.2580	0.2350	0.2607	0.2400	0.2662	0.2400	0.2635	0.2350
	6D	0.2607	0.2400	0.2634	0.2450	0.2689	0.2450	0.2662	0.2400
	6E	0.2634	0.2450	0.2661	0.2500	0.2716	0.2500	0.2689	0.2450
	6F	0.2661	0.2500	0.2688	0.2550	0.2743	0.2550	0.2716	0.2500
	6G	0.2688	0.2550	0.2716	0.2600	0.2771	0.2600	0.2743	0.2550
	6H	0.2716	0.2600	0.2743	0.2650	0.2798	0.2650	0.2771	0.2600
	6J	0.2743	0.2650	0.2770	0.2700	0.2825	0.2700	0.2798	0.2650
	6K	0.2770	0.2700	0.2797	0.2750	0.2852	0.2750	0.2825	0.2700
	6L	0.2797	0.2750	0.2824	0.2800	0.2879	0.2800	0.2852	0.2750
	6M	0.2824	0.2800	0.2852	0.2850	0.2907	0.2850	0.2879	0.2800
	6N	0.2852	0.2850	0.2879	0.2900	0.2934	0.2900	0.2907	0.2850
	6P	0.2879	0.2900	0.2906	0.2950	0.2961	0.2950	0.2934	0.2900
	6Q	0.2906	0.2950	0.2933	0.3000	0.2988	0.3000	0.2961	0.2950
	6R	0.2933	0.3000	0.2960	0.3050	0.3015	0.3050	0.2988	0.3000
	7A	0.2580	0.2250	0.2608	0.2300	0.2661	0.2300	0.2634	0.2250
	7B	0.2608	0.2300	0.2635	0.2350	0.2688	0.2350	0.2661	0.2300
	7C	0.2635	0.2350	0.2662	0.2400	0.2716	0.2400	0.2688	0.2350
	7D	0.2662	0.2400	0.2689	0.2450	0.2743	0.2450	0.2716	0.2400
	7E	0.2689	0.2450	0.2716	0.2500	0.2770	0.2500	0.2743	0.2450
	7F	0.2716	0.2500	0.2743	0.2550	0.2797	0.2550	0.2770	0.2500
	7G	0.2743	0.2550	0.2771	0.2600	0.2824	0.2600	0.2797	0.2550
	7H	0.2771	0.2600	0.2798	0.2650	0.2852	0.2650	0.2824	0.2600
	7J	0.2798	0.2650	0.2825	0.2700	0.2879	0.2700	0.2852	0.2650
	7K	0.2825	0.2700	0.2852	0.2750	0.2906	0.2750	0.2879	0.2700
	7L	0.2852	0.2750	0.2879	0.2800	0.2933	0.2800	0.2906	0.2750
	7M	0.2879	0.2800	0.2907	0.2850	0.2960	0.2850	0.2933	0.2800
	7N	0.2907	0.2850	0.2934	0.2900	0.2987	0.2900	0.2960	0.2850
	7P	0.2934	0.2900	0.2961	0.2950	0.3015	0.2950	0.2987	0.2900
	7Q	0.2961	0.2950	0.2988	0.3000	0.3042	0.3000	0.3015	0.2950
	7R	0.2988	0.3000	0.3015	0.3050	0.3069	0.3050	0.3042	0.3000

Note 10

Note 10 Tolerance each rank : ±0.005

Specifications

BXFW115MCR-300-TR

【Sorting chart for Chromaticity coordinates, x,y】

LEDs shall be sorted out into following chart and each rank parts shall be packed separately when shipping.

(I_F=30mA, T_a=25°C)

λpランク λp Rank	ランク/Rank	Point 1		Point 2		Point 3		Point 4	
		x	y	x	y	x	y	x	y
5	6A	0.2525	0.2250	0.2553	0.2300	0.2608	0.2300	0.2580	0.2250
	6B	0.2553	0.2300	0.2580	0.2350	0.2635	0.2350	0.2608	0.2300
	6C	0.2580	0.2350	0.2607	0.2400	0.2662	0.2400	0.2635	0.2350
	6D	0.2607	0.2400	0.2634	0.2450	0.2689	0.2450	0.2662	0.2400
	6E	0.2634	0.2450	0.2661	0.2500	0.2716	0.2500	0.2689	0.2450
	6F	0.2661	0.2500	0.2688	0.2550	0.2743	0.2550	0.2716	0.2500
	6G	0.2688	0.2550	0.2716	0.2600	0.2771	0.2600	0.2743	0.2550
	6H	0.2716	0.2600	0.2743	0.2650	0.2798	0.2650	0.2771	0.2600
	6J	0.2743	0.2650	0.2770	0.2700	0.2825	0.2700	0.2798	0.2650
	6K	0.2770	0.2700	0.2797	0.2750	0.2852	0.2750	0.2825	0.2700
	6L	0.2797	0.2750	0.2824	0.2800	0.2879	0.2800	0.2852	0.2750
	6M	0.2824	0.2800	0.2852	0.2850	0.2907	0.2850	0.2879	0.2800
	6N	0.2852	0.2850	0.2879	0.2900	0.2934	0.2900	0.2907	0.2850
	6P	0.2879	0.2900	0.2906	0.2950	0.2961	0.2950	0.2934	0.2900
	6Q	0.2906	0.2950	0.2933	0.3000	0.2988	0.3000	0.2961	0.2950
	6R	0.2933	0.3000	0.2960	0.3050	0.3015	0.3050	0.2988	0.3000
	7A	0.2580	0.2250	0.2608	0.2300	0.2661	0.2300	0.2634	0.2250
	7B	0.2608	0.2300	0.2635	0.2350	0.2688	0.2350	0.2661	0.2300
	7C	0.2635	0.2350	0.2662	0.2400	0.2716	0.2400	0.2688	0.2350
	7D	0.2662	0.2400	0.2689	0.2450	0.2743	0.2450	0.2716	0.2400
7E	0.2689	0.2450	0.2716	0.2500	0.2770	0.2500	0.2743	0.2450	
7F	0.2716	0.2500	0.2743	0.2550	0.2797	0.2550	0.2770	0.2500	
7G	0.2743	0.2550	0.2771	0.2600	0.2824	0.2600	0.2797	0.2550	
7H	0.2771	0.2600	0.2798	0.2650	0.2852	0.2650	0.2824	0.2600	
7J	0.2798	0.2650	0.2825	0.2700	0.2879	0.2700	0.2852	0.2650	
7K	0.2825	0.2700	0.2852	0.2750	0.2906	0.2750	0.2879	0.2700	
7L	0.2852	0.2750	0.2879	0.2800	0.2933	0.2800	0.2906	0.2750	
7M	0.2879	0.2800	0.2907	0.2850	0.2960	0.2850	0.2933	0.2800	
7N	0.2907	0.2850	0.2934	0.2900	0.2987	0.2900	0.2960	0.2850	
7P	0.2934	0.2900	0.2961	0.2950	0.3015	0.2950	0.2987	0.2900	
7Q	0.2961	0.2950	0.2988	0.3000	0.3042	0.3000	0.3015	0.2950	
7R	0.2988	0.3000	0.3015	0.3050	0.3069	0.3050	0.3042	0.3000	

Note 10

Note 10 Tolerance each rank : ±0.005

Specifications

BXFW115MCR-300-TR

【Sorting chart for Chromaticity coordinates, x,y】

LEDs shall be sorted out into following chart and each rank parts shall be packed separately when shipping.

(I_F=30mA, Ta=25°C)

λpランク λp Rank	ランク/Rank	Point 1		Point 2		Point 3		Point 4	
		x	y	x	y	x	y	x	y
6	6A	0.2525	0.2250	0.2553	0.2300	0.2608	0.2300	0.2580	0.2250
	6B	0.2553	0.2300	0.2580	0.2350	0.2635	0.2350	0.2608	0.2300
	6C	0.2580	0.2350	0.2607	0.2400	0.2662	0.2400	0.2635	0.2350
	6D	0.2607	0.2400	0.2634	0.2450	0.2689	0.2450	0.2662	0.2400
	6E	0.2634	0.2450	0.2661	0.2500	0.2716	0.2500	0.2689	0.2450
	6F	0.2661	0.2500	0.2688	0.2550	0.2743	0.2550	0.2716	0.2500
	6G	0.2688	0.2550	0.2716	0.2600	0.2771	0.2600	0.2743	0.2550
	6H	0.2716	0.2600	0.2743	0.2650	0.2798	0.2650	0.2771	0.2600
	6J	0.2743	0.2650	0.2770	0.2700	0.2825	0.2700	0.2798	0.2650
	6K	0.2770	0.2700	0.2797	0.2750	0.2852	0.2750	0.2825	0.2700
	6L	0.2797	0.2750	0.2824	0.2800	0.2879	0.2800	0.2852	0.2750
	6M	0.2824	0.2800	0.2852	0.2850	0.2907	0.2850	0.2879	0.2800
	6N	0.2852	0.2850	0.2879	0.2900	0.2934	0.2900	0.2907	0.2850
	6P	0.2879	0.2900	0.2906	0.2950	0.2961	0.2950	0.2934	0.2900
	6Q	0.2906	0.2950	0.2933	0.3000	0.2988	0.3000	0.2961	0.2950
	6R	0.2933	0.3000	0.2960	0.3050	0.3015	0.3050	0.2988	0.3000
	7A	0.2580	0.2250	0.2608	0.2300	0.2661	0.2300	0.2634	0.2250
	7B	0.2608	0.2300	0.2635	0.2350	0.2688	0.2350	0.2661	0.2300
	7C	0.2635	0.2350	0.2662	0.2400	0.2716	0.2400	0.2688	0.2350
	7D	0.2662	0.2400	0.2689	0.2450	0.2743	0.2450	0.2716	0.2400
	7E	0.2689	0.2450	0.2716	0.2500	0.2770	0.2500	0.2743	0.2450
	7F	0.2716	0.2500	0.2743	0.2550	0.2797	0.2550	0.2770	0.2500
	7G	0.2743	0.2550	0.2771	0.2600	0.2824	0.2600	0.2797	0.2550
	7H	0.2771	0.2600	0.2798	0.2650	0.2852	0.2650	0.2824	0.2600
	7J	0.2798	0.2650	0.2825	0.2700	0.2879	0.2700	0.2852	0.2650
	7K	0.2825	0.2700	0.2852	0.2750	0.2906	0.2750	0.2879	0.2700
	7L	0.2852	0.2750	0.2879	0.2800	0.2933	0.2800	0.2906	0.2750
	7M	0.2879	0.2800	0.2907	0.2850	0.2960	0.2850	0.2933	0.2800
	7N	0.2907	0.2850	0.2934	0.2900	0.2987	0.2900	0.2960	0.2850
	7P	0.2934	0.2900	0.2961	0.2950	0.3015	0.2950	0.2987	0.2900
	7Q	0.2961	0.2950	0.2988	0.3000	0.3042	0.3000	0.3015	0.2950
	7R	0.2988	0.3000	0.3015	0.3050	0.3069	0.3050	0.3042	0.3000

Note 10

Note 10 Tolerance each rank : ±0.005

Specifications

BXFW115MCR-300-TR

【Sorting chart for Chromaticity coordinates, x,y】

LEDs shall be sorted out into following chart and each rank parts shall be packed separately when shipping.

(I_F=30mA, T_a=25°C)

λpランク λp Rank	ランク/Rank	Point 1		Point 2		Point 3		Point 4	
		x	y	x	y	x	y	x	y
7	6A	0.2525	0.2250	0.2553	0.2300	0.2608	0.2300	0.2580	0.2250
	6B	0.2553	0.2300	0.2580	0.2350	0.2635	0.2350	0.2608	0.2300
	6C	0.2580	0.2350	0.2607	0.2400	0.2662	0.2400	0.2635	0.2350
	6D	0.2607	0.2400	0.2634	0.2450	0.2689	0.2450	0.2662	0.2400
	6E	0.2634	0.2450	0.2661	0.2500	0.2716	0.2500	0.2689	0.2450
	6F	0.2661	0.2500	0.2688	0.2550	0.2743	0.2550	0.2716	0.2500
	6G	0.2688	0.2550	0.2716	0.2600	0.2771	0.2600	0.2743	0.2550
	6H	0.2716	0.2600	0.2743	0.2650	0.2798	0.2650	0.2771	0.2600
	6J	0.2743	0.2650	0.2770	0.2700	0.2825	0.2700	0.2798	0.2650
	6K	0.2770	0.2700	0.2797	0.2750	0.2852	0.2750	0.2825	0.2700
	6L	0.2797	0.2750	0.2824	0.2800	0.2879	0.2800	0.2852	0.2750
	6M	0.2824	0.2800	0.2852	0.2850	0.2907	0.2850	0.2879	0.2800
	6N	0.2852	0.2850	0.2879	0.2900	0.2934	0.2900	0.2907	0.2850
	6P	0.2879	0.2900	0.2906	0.2950	0.2961	0.2950	0.2934	0.2900
	6Q	0.2906	0.2950	0.2933	0.3000	0.2988	0.3000	0.2961	0.2950
	6R	0.2933	0.3000	0.2960	0.3050	0.3015	0.3050	0.2988	0.3000
	7A	0.2580	0.2250	0.2608	0.2300	0.2661	0.2300	0.2634	0.2250
	7B	0.2608	0.2300	0.2635	0.2350	0.2688	0.2350	0.2661	0.2300
	7C	0.2635	0.2350	0.2662	0.2400	0.2716	0.2400	0.2688	0.2350
	7D	0.2662	0.2400	0.2689	0.2450	0.2743	0.2450	0.2716	0.2400
	7E	0.2689	0.2450	0.2716	0.2500	0.2770	0.2500	0.2743	0.2450
	7F	0.2716	0.2500	0.2743	0.2550	0.2797	0.2550	0.2770	0.2500
	7G	0.2743	0.2550	0.2771	0.2600	0.2824	0.2600	0.2797	0.2550
	7H	0.2771	0.2600	0.2798	0.2650	0.2852	0.2650	0.2824	0.2600
	7J	0.2798	0.2650	0.2825	0.2700	0.2879	0.2700	0.2852	0.2650
	7K	0.2825	0.2700	0.2852	0.2750	0.2906	0.2750	0.2879	0.2700
	7L	0.2852	0.2750	0.2879	0.2800	0.2933	0.2800	0.2906	0.2750
	7M	0.2879	0.2800	0.2907	0.2850	0.2960	0.2850	0.2933	0.2800
	7N	0.2907	0.2850	0.2934	0.2900	0.2987	0.2900	0.2960	0.2850
	7P	0.2934	0.2900	0.2961	0.2950	0.3015	0.2950	0.2987	0.2900
	7Q	0.2961	0.2950	0.2988	0.3000	0.3042	0.3000	0.3015	0.2950
	7R	0.2988	0.3000	0.3015	0.3050	0.3069	0.3050	0.3042	0.3000

Note 10

Note 10 Tolerance each rank : ±0.005

Specifications

【Sorting chart for Forward voltage characteristics, V_F 】

LEDs shall be sorted out into following chart and each rank parts shall be packed separately when shipping.

ランク Rank	順電圧 Forward voltage V_F (V)		条件 Conditions
	最小値 Min.	最大値 Max.	
B	5.2	5.4	$I_F=30\text{mA}$ $T_a=25^\circ\text{C}$
C	5.4	5.6	
D	5.6	5.8	
E	5.8	6.0	
F	6.0	6.2	

Note 11

Note 11 Tolerance each rank : $\pm 0.1\text{V}$

Technical Data

BXFW115MCR-300-TR

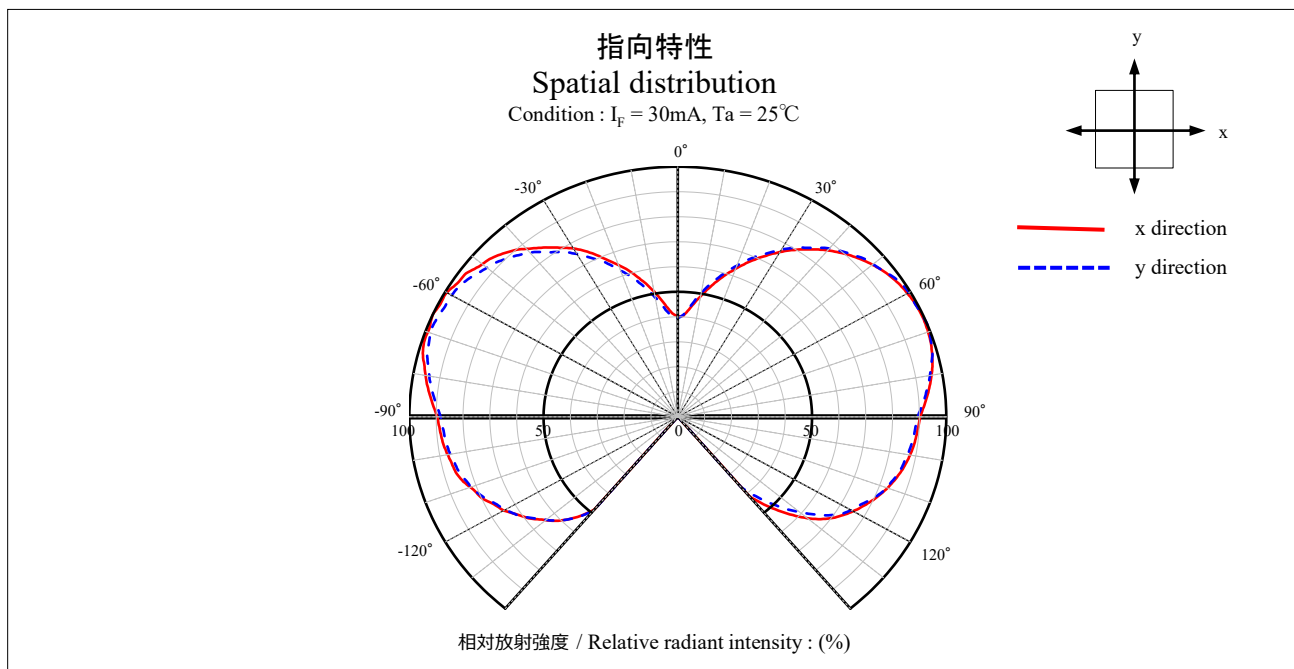
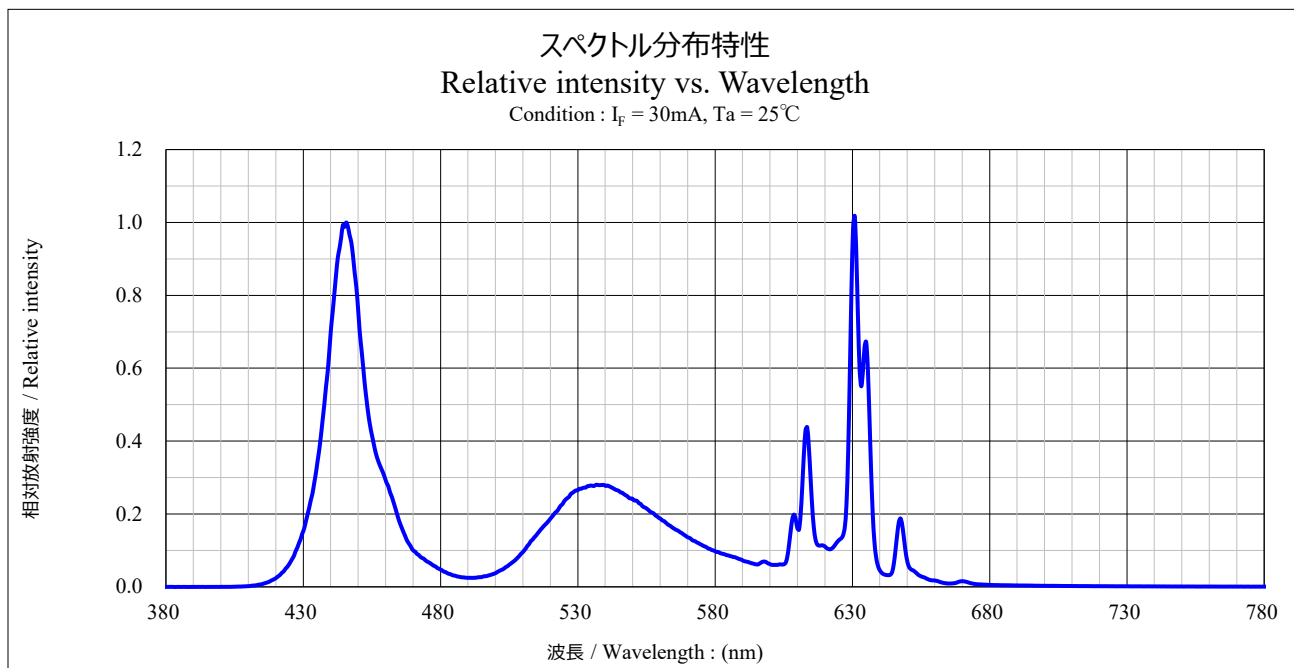

Technical Data

BXFW115MCR-300-TR

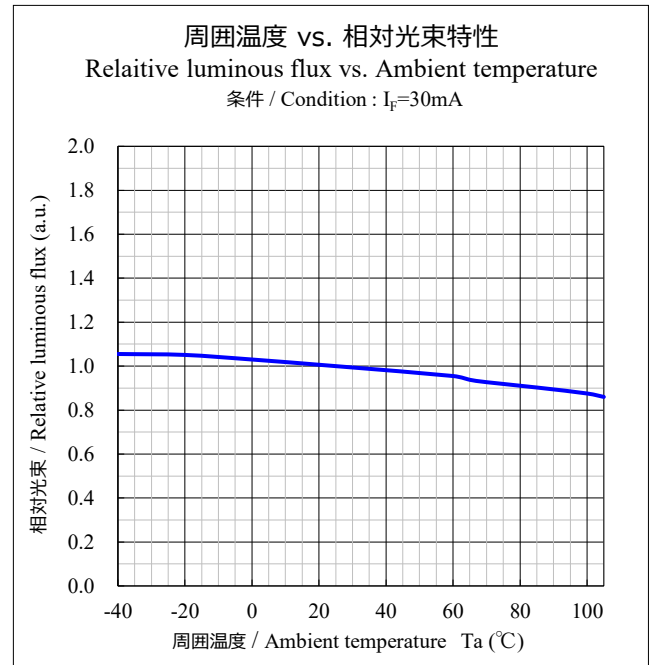
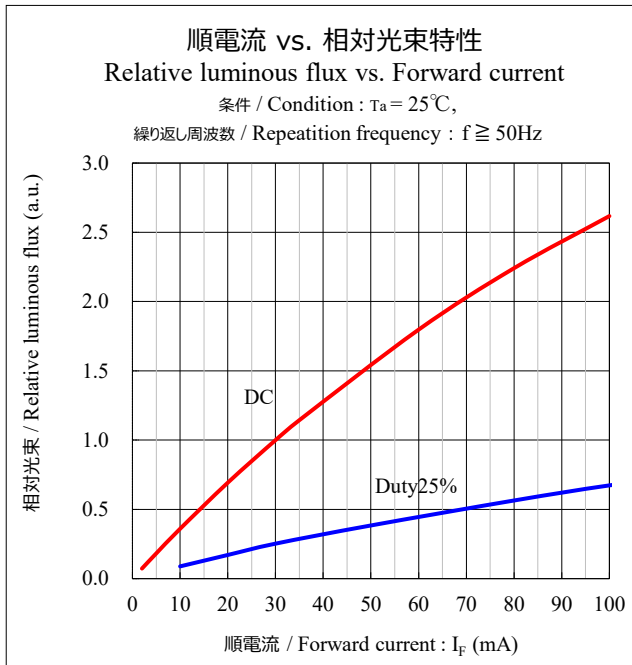
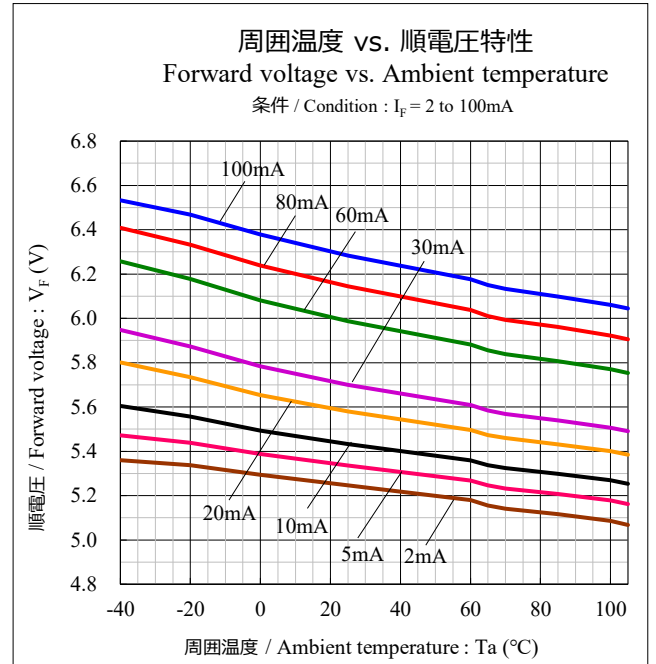
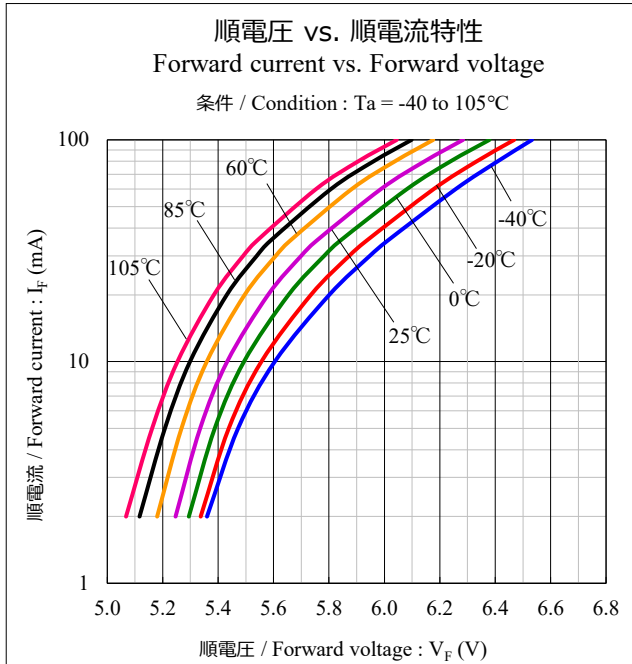

 Duty比 : $D = t/T$

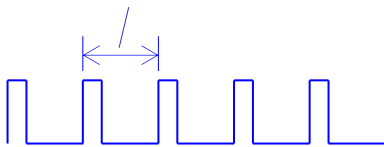
 周波数 / Repetition frequency : $= 1/T$

 周期 / cycle : T

 パルス幅 / pulse width : t

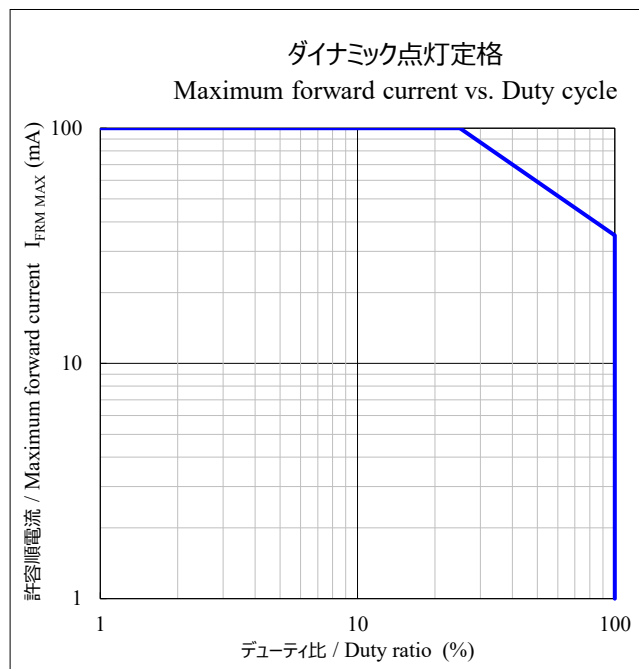
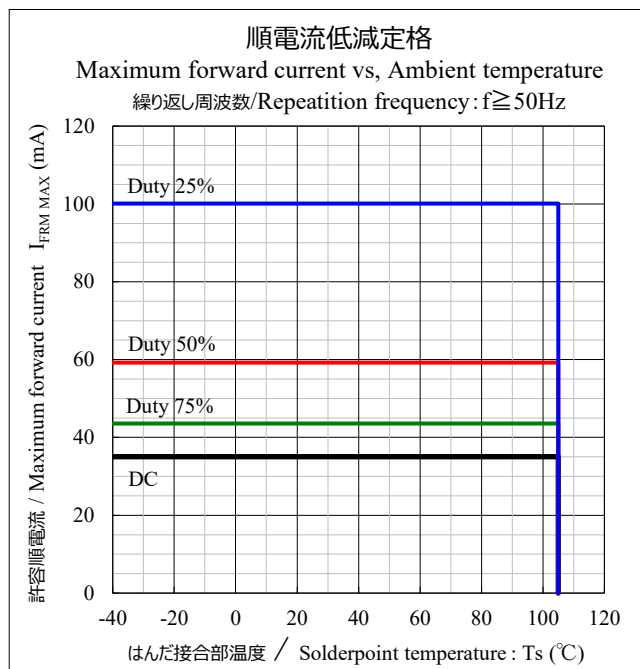
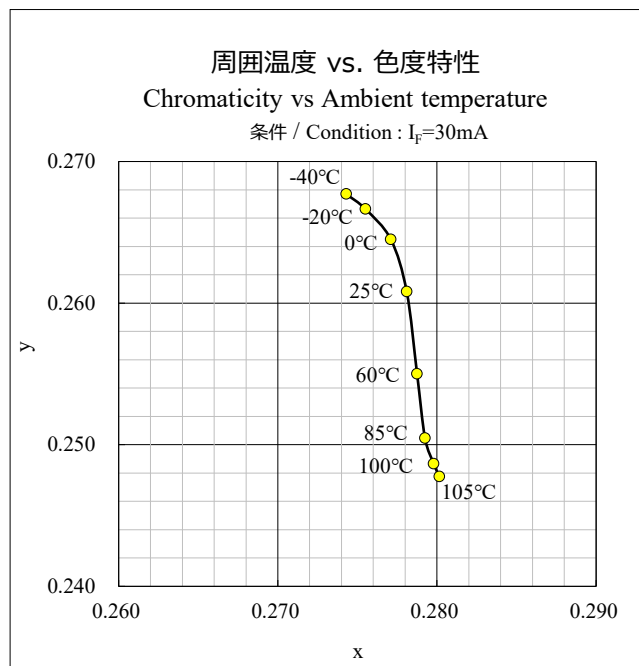
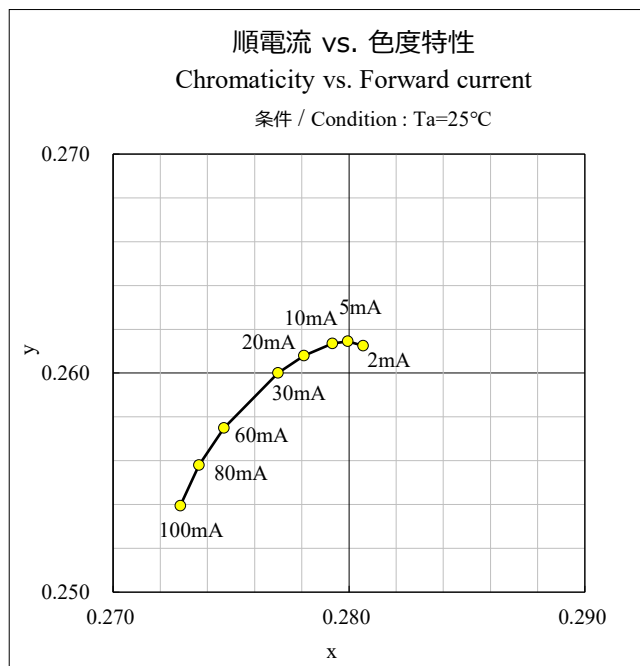
Technical Data

BXFW115MCR-300-TR



本データシート記載事項及び製品使用にあたってのお願いと注意事項

Special notice to customers using the products and technical information shown in this data sheet

- 1) データシートに記載している技術情報は、代表的応用例や特性等を示したもので、工業所有権等の実施に対する保証または実施権の許諾を行うものではありません。

The technical information shown in the data sheets are limited to the typical characteristics and circuit examples of the referenced products. It does not constitute the warranting of industrial property nor the granting of any license.

- 2) データシートに記載している製品、仕様、特性、データ等は、製品改良等のために予告なしに変更することがあります。ご使用の際には必ず最新の仕様書によりご確認ください。

For the purpose of product improvement, the specifications, characteristics and technical data described in the data sheets are subject to change without prior notice. Therefore, it is recommended that the most updated specifications be used in your design.

- 3) データシートに記載している製品のご使用に際しましては、最新の仕様書記載の最大定格、動作電源電圧範囲、放熱特性、その他使用上の注意事項等を遵守いただくようお願いいたします。
なお、仕様書記載の最大定格、動作電源電圧範囲、放熱特性その他使用上の注意事項等を逸脱した製品の使用に起因する損害に関しては、当社は責任を負いません。

When using the products described in the data sheets, please adhere to the maximum ratings for operating voltage, heat dissipation characteristics, and other precautions for use. We are not responsible for any damage which may occur if these specifications are exceeded.

- 4) データシートに記載している製品は、LCDバックライト光源に使用されることを目的として製造したものです。上記以外の用途にはお使いいただけません。

The products listed in the datasheet are manufactured for the purpose of being used as light sources for LCD backlights. They are not intended for applications other than those listed above.

- 5) データシートに記載している製品のうち「外国為替および外国貿易法」に該当するものを輸出するとき、または日本国外に持ち出すときは、日本政府の許可が必要です。

In order to export the products or technologies described in this data sheet which are under the “Foreign Exchange and foreign trade Control Law,” it is necessary to first obtain an export permit from the Japanese government.

- 6) データシートの全部または一部を転載または複製することはかたくお断りします。

No part of this data sheet may be reprinted or reproduced without prior written permission from Stanley Electric Co., Ltd.

- 7) このデータシートの最新版は下記のアドレスから入手できます。

ホームページアドレス：<https://www.stanley-electric.com/jp/products/>

The most updated edition of this data sheet can be obtained from the address below:

en <https://www.stanley-electric.com/en/products/>

cn <https://www.stanley-electric.cn/cn/products/>